

Tumble Dryers

25 Pound (11 Kilogram) Capacity

30 Pound (13 Kilogram) Capacity

35 Pound (16 Kilogram) Capacity

Stacked 30 Pound (13/13 Kilogram) Capacity

Stacked 45 Pound (20/20 Kilogram) Capacity

55 Pound (24 Kilogram) Capacity

18 Digit Model Numbers with 3 and 5 in 13th Position

Refer to Page 12 for Model Identification

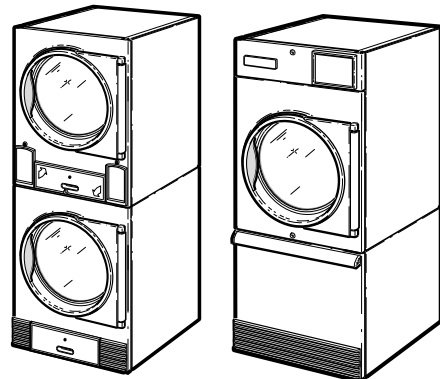

TMB1281C_SVG

Original Instructions

Keep These Instructions for Future Reference.

CAUTION: Read the instructions before using the machine.

(If this machine changes ownership, this manual must accompany machine.)

Installation must conform with local codes or, in the absence of local codes, with:

In the U.S.A., installation must conform to the latest edition of the American National Standard Z223.1/ NFPA 54 “National Fuel Gas Code” and Standard ANSI/NFPA 70 “National Electric Code.”

In Canada, installation must comply with Standards CAN/CSA-B149.1 Natural Gas and Propane Installation Code and CSA C22.1, latest edition, Canadian Electric Code, Part I.

In Australia and New Zealand, installation must comply with the Gas Installations Standard AS/NZS 5601 Part 1: General Installations.

In Europe, before installation, check that the local distribution conditions, nature of gas and pressure, and the adjustment of the appliance are compatible.

This equipment has been designed and certified to comply with IEC/EN 60335 electrical safety standards for tumble dryers.



Read all instructions before using tumble dryer.

IMPORTANT: If it is unavoidable that fabrics that contain vegetable or cooking oil or have been contaminated by hair care products be placed in a tumble dryer, they should first be washed in hot water with extra detergent. This will reduce, but not eliminate, the hazard.

	WARNING
FOR YOUR SAFETY, the information in this manual must be followed to minimize the risk of fire or explosion or to prevent property damage, personal injury or death.	
W033	

	DANGER
Electric shock hazard will result in death or serious injury. Disconnect all electric power to appliance and accessories and wait five (5) minutes before servicing.	
W925	

Units are IPx4 when enclosed per these instructions.

	WARNING
<ul style="list-style-type: none">• Do not store or use gasoline or other flammable vapors and liquids in the vicinity of this or any other appliance.• WHAT TO DO IF YOU SMELL GAS:<ul style="list-style-type: none">• Do not try to light any appliance.• Do not touch any electrical switch; do not use any phone in your building.• Clear the room, building or area of all occupants.• Immediately call your gas supplier from a neighbor's phone. Follow the gas supplier's instructions.• If you cannot reach your gas supplier, call the fire department.• Installation and service must be performed by a qualified installer, service agency or the gas supplier.	
W052	

IMPORTANT: Information must be obtained from a local gas supplier on instructions to be followed if the user smells gas. These instructions must be posted in a prominent location. Step-by-step instructions of the above safety information must be posted in a prominent location near the tumble dryer for customer use.

IMPORTANT: Post the following statement in a prominent location

FOR YOUR SAFETY

Do not store or use gasoline or other flammable vapors and liquids in the vicinity of this or any other appliance.

IMPORTANT: The installer must fully test the tumble dryer after installation and demonstrate to the owner how to operate the machine.

IMPORTANT: The machine shall only be installed in a room separated from inhabited rooms, incorporating appropriate ventilation specified in the National Installation Regulations.

IMPORTANT: The tumble dryer is not to be used if industrial chemicals have been used for cleaning.



WARNING

To reduce the risk of electric shock, fire, explosion, serious injury or death:

- Disconnect electric power to the tumble dryer before servicing.
- Close gas shut-off valve to gas tumble dryer before servicing.
- Close steam valve to steam tumble dryer before servicing.
- Never start the tumble dryer with any guards/panels removed.
- Whenever ground wires are removed during servicing, these ground wires must be reconnected to ensure that the tumble dryer is properly grounded.

W002R1



WARNING

- Installation of unit must be performed by a qualified installer.
- Install tumble dryer according to manufacturer's instructions and local codes.
- DO NOT install a tumble dryer with flexible plastic venting materials. If flexible metal (foil type) duct is installed, it must be of a specific type identified by the appliance manufacturer as suitable for use with tumble dryer. Refer to section on connecting exhaust system. Flexible venting materials are known to collapse, be easily crushed, and trap lint. These conditions will obstruct tumble dryer airflow and increase the risk of fire.

W752R1



CAUTION

TO AVOID THE RISK OF FIRE THIS DRYER MUST BE EXHAUSTED OUTDOORS.

W928



WARNING

To reduce the risk of serious injury: Avoid contact with hot surfaces.

W927



WARNING

Electrical shock hazard can cause death or serious injury. To reduce the risk of electric shock, disconnect all electric power to appliance and accessories before servicing.

W929



WARNING

Moving parts hazard can cause serious injury. Disconnect electric power to unit before servicing. Unexpected start of machinery will occur if the unit is equipped with the extended tumble feature.

W937



WARNING

Lint compartment must be cleaned daily

To avoid the risk of fire:

- Use for drying water washed fabrics only.
- DO NOT dry articles containing foam rubber, plastic, or similarly textured rubber like materials.
- DO NOT put articles soiled with cooking oil in dryer as cooking oil may not be removed during washing. Due to the remaining oil the fabric may catch on fire by itself.
- DO NOT put articles soiled with flammable liquids or flammable cleaning solvents in dryer.

W930



CAUTION

- Risk of fire, a clothes dryer produces combustible lint. Exhaust outdoors. Care should be taken to prevent the accumulation of lint around the exhaust opening and in the surrounding area.
- DO NOT reach into the dryer until all moving parts have stopped.
- DO NOT let children play on or in the dryer.

W931

In Australia and New Zealand:



WARNING

- **DO NOT operate this appliance before reading the instruction booklet.**
- **DO NOT place articles on or against this appliance.**
- **DO NOT store chemicals or flammable materials or spray aerosols near this appliance.**
- **DO NOT operate with panels, covers or guards removed from this appliance.**
- **DO NOT load materials containing flammable solvents into this appliance.**
- **If repeated ignition reset is required, the dryer should not be used and a service call booked.**



Risk of fire/flammable material.

W926

The following information applies to the state of Massachusetts, USA.

- This appliance can only be installed by a Massachusetts licensed plumber or gas fitter.
- This appliance must be installed with a 36 inch [91 cm] long flexible gas connector.
- A “T-Handle” type gas shut-off valve must be installed in the gas supply line to this appliance.
- This appliance must not be installed in a bedroom or bathroom.

Regulatory Statements

PRODUCT COMPLIANCE

Users of this product are cautioned not to make modifications or changes that are not approved by Alliance Laundry Systems, LLC. Doing so may void the compliance of this product with applicable laws and regulatory requirements and may result in the loss of the user’s authority to operate the equipment.

UNITED STATES

This device complies with Part 15 of the FCC Rules. Operation is subject to the following two conditions; (1) This device may not cause harmful interference, and (2) this device must accept any interference received, including interference that may cause undesired operation.

This equipment has been tested and found to comply with the limits for a Class B digital device, pursuant to Part 15 of the FCC Rules. These limits are designed to provide reasonable protection against harmful interference in a residential installation. This equipment generates uses and can radiate radio frequency energy and, if not installed and used in accordance with the instructions, may cause harmful interference to radio communications. How-

ever, there is no guarantee that interference will not occur in a particular installation. If this equipment does cause harmful interference to radio or television reception, which can be determined by turning the equipment off and on, the user is encouraged to try to correct the interference by one or more of the following measures:

- Reorient or relocate the radio or television receiving antenna.
- Increase the separation between the computer equipment or receiver.
- Connect the equipment into an outlet on a circuit different from that to which the radio or television receiver is connected.
- Consult the dealer or experienced radio television technician for help.



CAUTION

To comply with the limits of the Class B device, pursuant to Part 15 of the FCC Rules, this device is to comply with Class B limits. All peripherals must be shielded and grounded. Operation with non-certified peripherals or non-shielded cables is likely to result in interference and reception of the device.

W1004

Radiation Exposure Statement: This equipment complies with FCC radiation exposure limits set forth for an uncontrolled environment. The radio installed in this equipment and is intended to operate with minimum distance 20cm between the radiator and your body.

Limited Channels Fixed For Use In USA: IEEE 802.11b or 802.11g or 802.11n(HT20) operation of this product in the U.S. is firmware-limited to Channel 1 through 11.

CANADA - CAN ICES-3(B)/NMB-3(B)

This device contains license-exempt transmitter(s)/receiver(s) that comply with Innovation, Science and Economic Development Canada’s license-exempt RSS(s) standards. Operation is subject to the following two conditions:

- This device may not cause interference.
- This device must accept any interference, including interference that may cause undesired operation of the device.

Radiation Exposure Statement: This equipment complies with Innovation, Science and Economic Development Canada’s radiation exposure limits set forth for in RSS-102. The radio installed in this equipment is installed and is intended to operate with minimum distance 20cm between the radiator and your body.

EUROPE

Products bearing the CE mark comply with the following EU directives:

- EMC Directive 2014/30/EU

- Machinery Directive 2006/42/EC
- Gas Appliance Directive 2016/426/EU
- RoHS Directive 2011/65/EU and its amendment directives; Commission Delegated Directive 2015/863 to restrict four phthalates

If the product has telecommunications functionality, it also complies with the requirements of the following EU directive:

- Radio Equipment Directive 2014/53/EU

Compliance with these Directives implies conformity to harmonized European standards that are noted in the EU Declaration of Conformity which is available upon request.

Alliance Laundry Systems products comply with the requirement of Article 12 as it can be operated in at least one Member State as examined and the product is compliant with Article 11 as it has no restrictions on putting into service in all EU member states.

This device contains a 2.4GHz transceiver, intended for indoor use only in all EU member states, EFTA states, and Switzerland. Attention has been given to allowed operational frequencies. For detailed information concerning installations in France, the user should contact the national spectrum authority in France (<http://www.arcep.fr/>)

Be aware that outdoor installations require special attention and will only be handled by trained and qualified installation personnel. No one from the general-public is permitted to install wireless products outdoors when external antennas, power and grounding must be installed for use.

AUSTRALIA/NEW ZEALAND

The radio in this equipment complies with and is certified to the Australian and New Zealand regulatory requirements.

BRAZIL ANATEL

This device is not entitled to protection against harmful interference and may not interfere with duly authorized systems.

CHINA SRRC

The radio device has received certification of conformance in accordance with the People's Republic of China State Radio Regulation Committee (SRRC) certification scheme. Integrations of this radio into a final product does not require additional radio certification provided installation instructions are followed. No changes are authorized to the radio or the antenna of the approved device.

JAPAN

This product is equipped with a certified wireless device pursuant to Article 2-1-19 of the Certification Ordinance. No changes are authorized to the radio or the antenna of the approved device.

MEXICO IFETEL

“The operation of this equipment is subject to the following two conditions: (1) it is possible that this equipment or device does not cause harmful interference and (2) this equipment or device must accept any interference, including that which may cause its unwanted operation.”

SOUTH KOREA (KC)

The radio device has received certification of conformance in accordance with the Radio Waves Act. Integration of this radio into a final product does not require additional radio certification provided installation instructions are followed. No changes are authorized to the radio or the antenna of the approved device.

TAIWAN

The information in this section applies to products bearing the Taiwan National Communications Commission mark:

This telecom equipment has complied with NCC regulations.

According to “Administrative Regulations of Low Power Radio Waves Radiated Devices:

Article 12 The low-power radio-frequency devices must not be altered by changing the frequency, enhancing emission power, adding external antenna, and modification of original design characteristic as well as function.

Article 14 The operation of the low-power radio-frequency devices is subject to the conditions that no harmful interference is caused. The user must stop operating the device immediately should harmful interference is caused and shall not resume until the condition causing the harmful interference has been corrected.

Moreover, the interference must be accepted that may be caused by the operation of an authorized communications, or ISM equipment. (1) Precautions (marked in the product manual and on outer packaging)

THAILAND

The information in this section applies to products approved by the Thailand National Communications Commission:

These telecommunication and device are compliance with the requirements of National Broadcasting and Telecommunication Commission.

Manufacturing Date

The manufacturing date for your unit can be found on the serial number. The first two digits indicate the year. The third and fourth digits indicate the month. For example, a unit with serial number 1505000001 was manufactured in May 2015.

China Restriction of hazardous substances (RoHS)

The Table of Hazardous Substances/Elements and their Content

As required by China's Management Methods for Restricted Use of Hazardous Substances in Electrical and Electronic Products

Hazardous substances						
Part Name	Lead (Pb)	Mercury (Hg)	Cadmium (Cd)	Hexavalent Chromium (CR[VI])	Polybrominated biphenyls (PBB)	Polybrominated diphenyl ethers (PBDE)
PCBs	X	O	O	O	O	O
Electromechanical Parts	O	O	O	O	O	O
Cables and Wires	O	O	O	O	O	O
Metal Parts	O	O	O	O	O	O
Plastic Parts	O	O	O	O	O	O
Batteries	O	O	O	O	O	O
Textile	O	O	O	O	O	O
Timing Belts	O	O	O	O	O	O
Insulation	O	O	O	O	O	O
Glass	O	O	O	O	O	O
Display	O	O	O	O	O	O

This table is prepared in accordance with the provisions of SJ/T-11364.

O: Indicates that the content of said hazardous substance in all of the homogenous materials in the component is within the limits required by GB/T 26572.

X: Indicates that the content of said hazardous substance exceeds the limits required by GB/T 26572 in at least one homogenous material in the component.

All parts named in this table with an "X" are in compliance with the European Union's RoHS Legislation.

NOTE: The referenced Environmental Protection Use Period Marking was determined according to normal operating use conditions of the product such as temperature and humidity.



This product under normal use, durable years of environmental protection is 15 years.

Safety Information

Important Safety Instructions

	WARNING
<p>To reduce the risk of fire, electric shock, serious injury or death to persons when using your tumble dryer, follow these basic precautions.</p>	
W776R1	

Save These Instructions

- Read all instructions before using the tumble dryer.
- Install the tumble dryer according to the INSTALLATION instructions. Refer to the EARTHING (grounding) instructions for the proper earthing (grounding) of the tumble dryer. All connections for electrical power, earthing (grounding) and gas supply must comply with local codes and be made by licensed personnel when required. It is recommended that the machine be installed by qualified technicians.
- Do not install or store the tumble dryer where it will be exposed to water and/or weather. The tumble dryer cannot be used in a closed room where the air supply is insufficient. If necessary, ventilation grids must be installed in the doors or the windows.
- This tumble dryer must not be activated without lint screen filter.
- When you perceive a gas odor, immediately shut off the gas supply and ventilate the room. Do not power on electrical appliances and do not pull electrical switches. Do not use matches or lighters. Do not use a phone in the building. Warn the installer, and if so desired, the gas company, as soon as possible.
- To avoid fire and explosion, keep surrounding areas free of flammable and combustible products. Regularly clean the cylinder and exhaust tube should be cleaned periodically by competent maintenance personnel. Daily remove debris from lint screen filter and inside of filter compartment.
- Do not use or store flammable materials near this appliance.
- Do not place into tumble dryer articles that have been previously cleaned in, washed in, soaked in or spotted with gasoline or machine oils, vegetable or cooking oils, cleaning waxes or chemicals, dry-cleaning solvents, thinner or other flammable or explosive substances as they give off vapors that could ignite, explode or cause fabric to catch on fire by itself.
- Do not spray aerosols in the vicinity of this appliance while it is in operation.
- Items such as foam rubber (latex foam), shower caps, waterproof textiles, rubber backed articles and clothes or pillows filled with foam rubber pads should not be dried in the tumble dryer. Do not use the appliance to dry materials with a low melting temperature (PVC, rubber, etc.).
- Do not tumble fiberglass curtains and draperies unless the label says it can be done. If they are dried, wipe out the cylinder with a damp cloth to remove particles of fiberglass.
- Do not allow children to play on or in the dryer. Close supervision of children is necessary when the dryer is used near children. This appliance is not intended for use by persons (including children) with reduced physical, sensory or mental capabilities, or lack of experience and knowledge, unless they have been given supervision or instruction concerning the use of the appliance by a person responsible for their safety. This is a safety rule for all appliances.
- Cleaning and user maintenance shall not be made by children without supervision.
- Children less than three years should be kept away unless continuously supervised.
- Do not reach into the tumble dryer if the cylinder is revolving.
- Use tumble dryer only for its intended purpose, drying fabrics. Always follow the fabric care instructions supplied by the textile manufacturer and only use the dryer to dry textiles that have been washed in water. Only insert spin-dried linen in the dryer to avoid damage to dryer.
- Always read and follow manufacturer's instructions on packages of laundry and cleaning aids. Follow all warnings or precautions. To reduce the risk of poisoning or chemical burns, keep them out of the reach of children at all times (preferably in a locked cabinet).
- Do not use fabric softeners or products to eliminate static unless recommended by the manufacturer of the fabric softener or product.
- Remove laundry immediately after tumble dryer stops.
- DO NOT operate the tumble dryer if it is smoking, grinding or has missing or broken parts or removed guards or panels. DO NOT tamper with the controls or bypass any safety devices.
- Tumble dryer will not operate with the loading door open. DO NOT bypass the door safety switch to permit the tumble dryer to operate with the door open. The tumble dryer will stop rotating when the door is opened. Do not use the tumble dryer if it does not stop rotating when the door is opened or starts tumbling without pressing the START mechanism. Remove the tumble dryer from use and call for service.
- Tumble dryer will not operate with lint panel open. DO NOT bypass lint panel door safety switch to permit the tumble dryer to operate with the lint panel door open.
- Do not alter this tumble dryer from factory construction except as otherwise described in the technical instructions.
- Always clean the lint filter daily. Keep area around the exhaust opening and adjacent surrounding area free from the accumulation of lint, dust and dirt. The interior of the tumble dryer and the exhaust duct should be cleaned periodically by qualified service personnel.
- Solvent vapors from dry-cleaning machines create acids when drawn through the heater of the drying unit. These acids are corrosive to the tumble dryer as well as the laundry load being dried. Be sure make-up air is free of solvent vapors.

- At the end of each working day, close off all main supplies of gas, steam and electricity.

IMPORTANT: For fire suppression equipped tumble dryers, electricity and water should NOT be turned off.

- Do not repair or replace any part of the tumble dryer, or attempt any servicing unless specifically recommended in the user-maintenance instructions or in published user-repair instructions that the user understands and has the skills to carry out. ALWAYS disconnect and lockout the electrical power to the tumble dryer before servicing. Disconnect power by shutting off appropriate breaker or fuse.
- Activation of the emergency stop switch stops all tumble dryer control circuit functions, but DOES NOT remove all electrical power from tumble dryer.
- Exhaust ductwork should be examined and cleaned annually after installation.
- Before the tumble dryer is removed from service or discarded, remove the door to the drying compartment and the door to the lint compartment.
- Failure to install, maintain, and/or operate this tumble dryer according to the manufacturer’s instructions may result in conditions which can produce bodily injury and/or property damage.



NOTE: The WARNINGS and IMPORTANT SAFETY INSTRUCTIONS appearing in this manual are not meant to cover all possible conditions and situations that may occur. Observe and be aware of other labels and precautions that are located on the machine. They are intended to provide instruction for safe use of the machine. Common sense, caution and care must be exercised when installing, maintaining, or operating the tumble dryer.

Always contact your dealer, distributor, service agent or the manufacturer about any problems or conditions you do not understand.

NOTE: All appliances are produced according to the EMC-directive (Electro-Magnetic-Compatibility). They can be used in restricted surroundings only (comply minimally with class A requirements). For safety reasons there must be kept the necessary precaution distances with sensitive electrical or electronic device(s). These machines are not intended for domestic use by private consumers in the home environment.

Explanation of Safety Messages

Precautionary statements (“DANGER,” “WARNING,” and “CAUTION”), followed by specific instructions, are found in this manual and on machine decals. These precautions are intended for the personal safety of the operator, user, servicer, and those maintaining the machine.

	DANGER
Indicates an imminently hazardous situation that, if not avoided, will cause severe personal injury or death.	
	WARNING
Indicates a hazardous situation that, if not avoided, could cause severe personal injury or death.	
	CAUTION
Indicates a hazardous situation that, if not avoided, may cause minor or moderate personal injury or property damage.	

Additional precautionary statements (“IMPORTANT” and “NOTE”) are followed by specific instructions.

IMPORTANT: The word “IMPORTANT” is used to inform the reader of specific procedures where minor machine damage will occur if the procedure is not followed.

NOTE: The word “NOTE” is used to communicate installation, operation, maintenance or servicing information that is important but not hazard related.

Table of Contents

Safety Information.....	8
Important Safety Instructions.....	8
Explanation of Safety Messages.....	9
Introduction.....	12
Machine Identification.....	12
Contact Information.....	19
Specifications and Dimensions.....	21
Specifications and Dimensions.....	21
Cabinet Dimensions – 025, 030, 035 and 055 Series.....	26
Cabinet Dimensions – T30 and T45 Series.....	28
Exhaust Outlet Locations – 025, 030, 035 and 055 Series.....	29
Exhaust Outlet Locations – T30 and T45 Series.....	30
Gas Connection Locations – 025, 030, 035 and 055 Series.....	32
Gas Connection Locations – T30 and T45 Series.....	33
Electrical Connection Locations – 025, 030, 035 and 055 Series.....	34
Electrical Connection Locations – T30 and T45 Series.....	36
Steam Connection Locations – 025, 030 and 035 Series.....	37
Steam Connection Locations – T30 Series.....	38
Installation.....	39
Pre-Installation Inspection.....	39
Location Requirements.....	39
Position and Level the Tumble Dryer.....	40
Fifth Leveling Leg.....	41
Fire Suppression System (Optional Equipment).....	41
Check Local Codes and Permits.....	41
Water Requirements.....	41
Water Connections.....	42
Electrical Requirements.....	43
Auxiliary Alarm.....	43
To Reverse the Loading Door (025, 030, 035 and 055 Series) (Design 3 Only)...	43
Before Placing Tumble Dryer into Service.....	45
Required for IEC Models Only.....	47
Exhaust Requirements.....	48
Exhaust Requirements.....	48
Layout.....	48
Make-Up Air.....	48
Venting.....	48
Individual Venting.....	50

© Published by permission of the copyright owner.

All rights reserved. No part of the contents of this book may be reproduced or transmitted in any form or by any means without the expressed written consent of the publisher.

Manifold Venting.....	51
Gas Requirements.....	54
Gas Requirements.....	54
How to Change Burner Orifice Size.....	57
How to Adjust Gas Valve Governor/Regulator.....	59
Installing CE Gas Tumble Dryer.....	59
Adjusting Manifold Pressure for Natural Gas G20 or G25.....	60
Adjusting Supply Pressure for L.P.G. G30 or G31.....	60
Converting From Natural Gas to L.P.G. or From Unregulated L.P.G. to Regulated L.P.G.....	60
Start-Up Procedure.....	60
Gas Supply Pipe Sizing and Looping.....	61
Low Pressure Gas Pipe Sizes.....	62
High Pressure Gas Pipe Sizes.....	64
High Altitude Burner Orifice Sizing.....	66
Electrical Requirements.....	75
Electrical Requirements.....	75
Wiring Diagram.....	75
Wiring for Central Pay.....	75
Grounding Instructions.....	76
For On Premises Laundry (OPL) Models Only.....	76
Service/Ground Location.....	76
To Connect Electrical Service To Machine.....	78
Electrical Connections for T30 and T45 Only.....	78
Configuring Your Tumble Dryer for Other Service Voltages.....	78
Electrical Specifications.....	78
Steam Requirements.....	88
Steam Requirements.....	88
Piping Recommendations.....	90
Installing Steam Trap and Making Condensate Return Connections.....	90
Adjustments.....	91
Adjustments.....	91
Gas Burner Air Shutter.....	91
Airflow Switch	92
Loading Door Switch.....	92
Door Strike.....	93
Manual Resettable Thermostat.....	93
Before You Call for Service.....	94
Removing Tumble Dryer from Service.....	95
Disposal of Unit.....	96

Introduction

Machine Identification

Information in this manual is applicable to these machines. Refer to the serial plate.

25 Series (11 Kg)							
BA025E	BU025F	HG025E	HU025F	NJ025E	PK025N	SJ025R	UG025S
BA025F	BU025L	HG025F	HU025L	NJ025L	PR025E	SJ025S	UH025E
BA025L	BU025N	HG025L	HU025N	NJ025N	PR025S	SK025E	UH025F
BA025N	BU025R	HG025N	HU025R	NJ025S	PT025E	SK025F	UH025L
BA025R	BU025S	HG025R	HU025S	NK025E	PT025L	SK025L	UH025N
BA025S	GA025E	HG025S	KT025E	NK025L	PT025N	SK025N	UH025R
BG025D	GA025L	HH025E	KT025L	NK025N	PT025S	SK025R	UH025S
BG025E	GA025N	HH025F	KT025N	NR025E	PU025E	SL025E	UJ025D
BG025F	GA025S	HH025L	KT025S	NR025S	PU025L	SL025L	UJ025E
BG025L	GG025E	HH025N	MG025D	NT025E	PU025N	SR025E	UJ025F
BG025N	GG025L	HH025R	MG025E	NT025L	PU025S	SR025S	UJ025L
BG025R	GG025N	HH025S	MG025F	NT025N	SA025E	ST025E	UJ025N
BG025S	GG025S	HJ025D	MG025L	NT025S	SA025F	ST025F	UJ025R
BH025E	GH025E	HJ025E	MG025N	NU025E	SA025L	ST025L	UJ025S
BH025F	GH025L	HJ025F	MG025R	NU025L	SA025N	ST025N	UK025E
BH025L	GH025N	HJ025L	MG025S	NU025N	SA025R	ST025R	UK025F
BH025N	GH025S	HJ025N	MJ025D	NU025S	SA025S	ST025S	UK025L
BH025R	GJ025E	HJ025R	MJ025E	PA025E	SG025D	SU025E	UK025N
BH025S	GJ025L	HJ025S	MJ025F	PA025L	SG025E	SU025F	UK025R
BJ025D	GJ025N	HK025E	MJ025L	PA025N	SG025F	SU025L	UL025E
BJ025E	GJ025S	HK025F	MJ025N	PA025S	SG025L	SU025N	UL025L
BJ025F	GK025E	HK025L	MJ025R	PG025E	SG025N	SU025R	UR025E
BJ025L	GK025L	HK025N	MJ025S	PG025L	SG025R	SU025S	UR025S
BJ025N	GK025N	HK025R	NA025E	PG025N	SG025S	UA025E	UT025E
BJ025R	GU025E	HL025E	NA025L	PG025S	SH025E	UA025F	UT025F
BJ025S	GU025L	HL025L	NA025N	PH025E	SH025F	UA025L	UT025L
BK025E	GU025N	HR025E	NA025S	PH025L	SH025L	UA025N	UT025N
BK025F	GU025S	HR025S	NG025E	PH025N	SH025N	UA025R	UT025R

Table continues...

25 Series (11 Kg)							
BK025L	HA025E	HT025E	NG025L	PH025S	SH025R	UA025S	UT025S
BK025N	HA025F	HT025F	NG025N	PJ025E	SH025S	UG025D	UU025E
BK025R	HA025L	HT025L	NG025S	PJ025L	SJ025D	UG025E	UU025F
BL025E	HA025N	HT025N	NH025E	PJ025N	SJ025E	UG025F	UU025L
BL025L	HA025R	HT025R	NH025L	PJ025S	SJ025F	UG025L	UU025N
BR025E	HA025S	HT025S	NH025N	PK025E	SJ025L	UG025N	UU025R
BR025S	HG025D	HU025E	NH025S	PK025L	SJ025N	UG025R	UU025S
BU025E							
RT025E-IA	RT025F-IA	RT025L-IA	RT025N-IA	RT025R-IA	RT025S-IA	RT025T-IA	
RT025E-TA	RT025F-TA	RT025L-TA	RT025N-TA	RT025R-TA	RT025S-TA	RT025T-TA	

30 Series (13 Kg)							
BA030E	BU030F	HG030E	HU030F	NJ030E	PK030N	SJ030R	UG030S
BA030F	BU030L	HG030F	HU030L	NJ030L	PR030E	SJ030S	UH030E
BA030L	BU030N	HG030L	HU030N	NJ030N	PR030S	SK030E	UH030F
BA030N	BU030R	HG030N	HU030R	NJ030S	PT030E	SK030F	UH030L
BA030R	BU030S	HG030R	HU030S	NK030E	PT030L	SK030L	UH030N
BA030S	GA030E	HG030S	KT030E	NK030L	PT030N	SK030N	UH030R
BG030D	GA030L	HH030E	KT030L	NK030N	PT030S	SK030R	UH030S
BG030E	GA030N	HH030F	KT030N	NR030E	PU030E	SL030E	UJ030D
BG030F	GA030S	HH030L	KT030S	NR030S	PU030L	SL030L	UJ030E
BG030L	GG030E	HH030N	MG030D	NT030E	PU030N	SR030E	UJ030F
BG030N	GG030L	HH030R	MG030E	NT030L	PU030S	SR030S	UJ030L
BG030R	GG030N	HH030S	MG030F	NT030N	SA030E	ST030E	UJ030N
BG030S	GG030S	HJ030D	MG030L	NT030S	SA030F	ST030F	UJ030R
BH030E	GH030E	HJ030E	MG030N	NU030E	SA030L	ST030L	UJ030S
BH030F	GH030L	HJ030F	MG030R	NU030L	SA030N	ST030N	UK030E
BH030L	GH030N	HJ030L	MG030S	NU030N	SA030R	ST030R	UK030F
BH030N	GH030S	HJ030N	MJ030D	NU030S	SA030S	ST030S	UK030L
BH030R	GJ030E	HJ030R	MJ030E	PA030E	SG030D	SU030E	UK030N
BH030S	GJ030L	HJ030S	MJ030F	PA030L	SG030E	SU030F	UK030R
BJ030D	GJ030N	HK030E	MJ030L	PA030N	SG030F	SU030L	UL030E

Table continues...

30 Series (13 Kg)							
BJ030E	GJ030S	HK030F	MJ030N	PA030S	SG030L	SU030N	UL030L
BJ030F	GK030E	HK030L	MJ030R	PG030E	SG030N	SU030R	UR030E
BJ030L	GK030L	HK030N	MJ030S	PG030L	SG030R	SU030S	UR030S
BJ030N	GK030N	HK030R	NA030E	PG030N	SG030S	UA030E	UT030E
BJ030R	GU030E	HL030E	NA030L	PG030S	SH030E	UA030F	UT030F
BJ030S	GU030L	HL030L	NA030N	PH030E	SH030F	UA030L	UT030L
BK030E	GU030N	HR030E	NA030S	PH030L	SH030L	UA030N	UT030N
BK030F	GU030S	HR030S	NG030E	PH030N	SH030N	UA030R	UT030R
BK030L	HA030E	HT030E	NG030L	PH030S	SH030R	UA030S	UT030S
BK030N	HA030F	HT030F	NG030N	PJ030E	SH030S	UG030D	UU030E
BK030R	HA030L	HT030L	NG030S	PJ030L	SJ030D	UG030E	UU030F
BL030E	HA030N	HT030N	NH030E	PJ030N	SJ030E	UG030F	UU030L
BL030L	HA030R	HT030R	NH030L	PJ030S	SJ030F	UG030L	UU030N
BR030E	HA030S	HT030S	NH030N	PK030E	SJ030L	UG030N	UU030R
BR030S	HG030D	HU030E	NH030S	PK030L	SJ030N	UG030R	UU030S
BU030E							
RT030E-IA	RT030F-IA	RT030L-IA	RT030N-IA	RT030R-IA	RT030S-IA	RT030T-IA	
RT030E-TA	RT030F-TA	RT030L-TA	RT030N-TA	RT030R-TA	RT030S-TA	RT030T-TA	

T30 Series (13/13 Kg)							
BAT30E	BUT30F	HGT30E	HUT30F	NJT30E	PKT30N	SJT30R	UGT30S
BAT30F	BUT30L	HGT30F	HUT30L	NJT30L	PRT30E	SJT30S	UHT30E
BAT30L	BUT30N	HGT30L	HUT30N	NJT30N	PRT30S	SKT30E	UHT30F
BAT30N	BUT30R	HGT30N	HUT30R	NJT30S	PTT30E	SKT30F	UHT30L
BAT30R	BUT30S	HGT30R	HUT30S	NKT30E	PTT30L	SKT30L	UHT30N
BAT30S	GAT30E	HGT30S	KTT30E	NKT30L	PTT30N	SKT30N	UHT30R
BGT30D	GAT30L	HHT30E	KTT30L	NKT30N	PTT30S	SKT30R	UHT30S
BGT30E	GAT30N	HHT30F	KTT30N	NRT30E	PUT30E	SLT30E	UJT30D
BGT30F	GAT30S	HHT30L	KTT30S	NRT30S	PUT30L	SLT30L	UJT30E
BGT30L	GGT30E	HHT30N	MGT30D	NTT30E	PUT30N	SRT30E	UJT30F
BGT30N	GGT30L	HHT30R	MGT30E	NTT30L	PUT30S	SRT30S	UJT30L
BGT30R	GGT30N	HHT30S	MGT30F	NTT30N	SAT30E	STT30E	UJT30N

Table continues...

T30 Series (13/13 Kg)							
BGT30S	GGT30S	HJT30D	MGT30L	NTT30S	SAT30F	STT30F	UJT30R
BHT30E	GHT30E	HJT30E	MGT30N	NUT30E	SAT30L	STT30L	UJT30S
BHT30F	GHT30L	HJT30F	MGT30R	NUT30L	SAT30N	STT30N	UKT30E
BHT30L	GHT30N	HJT30L	MGT30S	NUT30N	SAT30R	STT30R	UKT30F
BHT30N	GHT30S	HJT30N	MJT30D	NUT30S	SAT30S	STT30S	UKT30L
BHT30R	GJT30E	HJT30R	MJT30E	PAT30E	SGT30D	SUT30E	UKT30N
BHT30S	GJT30L	HJT30S	MJT30F	PAT30L	SGT30E	SUT30F	UKT30R
BJT30D	GJT30N	HKT30E	MJT30L	PAT30N	SGT30F	SUT30L	ULT30E
BJT30E	GJT30S	HKT30F	MJT30N	PAT30S	SGT30L	SUT30N	ULT30L
BJT30F	GKT30E	HKT30L	MJT30R	PGT30E	SGT30N	SUT30R	URT30E
BJT30L	GKT30L	HKT30N	MJT30S	PGT30L	SGT30R	SUT30S	URT30S
BJT30N	GKT30N	HKT30R	NAT30E	PGT30N	SGT30S	UAT30E	UTT30E
BJT30R	GUT30E	HLT30E	NAT30L	PGT30S	SHT30E	UAT30F	UTT30F
BJT30S	GUT30L	HLT30L	NAT30N	PHT30E	SHT30F	UAT30L	UTT30L
BKT30E	GUT30N	HRT30E	NAT30S	PHT30L	SHT30L	UAT30N	UTT30N
BKT30F	GUT30S	HRT30S	NGT30E	PHT30N	SHT30N	UAT30R	UTT30R
BKT30L	HAT30E	HTT30E	NGT30L	PHT30S	SHT30R	UAT30S	UTT30S
BKT30N	HAT30F	HTT30F	NGT30N	PJT30E	SHT30S	UGT30D	UUT30E
BKT30R	HAT30L	HTT30L	NGT30S	PJT30L	SJT30D	UGT30E	UUT30F
BLT30E	HAT30N	HTT30N	NHT30E	PJT30N	SJT30E	UGT30F	UUT30L
BLT30L	HAT30R	HTT30R	NHT30L	PJT30S	SJT30F	UGT30L	UUT30N
BRT30E	HAT30S	HTT30S	NHT30N	PKT30E	SJT30L	UGT30N	UUT30R
BRT30S	HGT30D	HUT30E	NHT30S	PKT30L	SJT30N	UGT30R	UUT30S
BUT30E							
RTT30E-IA	RTT30F-IA	RTT30L-IA	RTT30N-IA	RTT30R-IA	RTT30S-IA	RTT30T-IA	
RTT30E-TA	RTT30F-TA	RTT30L-TA	RTT30N-TA	RTT30R-TA	RTT30S-TA	RTT30T-TA	

35 Series (16 Kg)							
BA035E	BU035L	HG035E	HU035M	NJ035L	PK035N	SJ035N	UG035R
BA035F	BU035M	HG035F	HU035N	NJ035M	PR035E	SJ035R	UG035S
BA035L	BU035N	HG035L	HU035R	NJ035N	PR035S	SJ035S	UH035E
BA035M	BU035R	HG035M	HU035S	NJ035S	PT035E	SK035E	UH035F

Table continues...

35 Series (16 Kg)							
BA035N	BU035S	HG035N	KT035E	NK035E	PT035L	SK035F	UH035L
BA035R	GA035E	HG035R	KT035L	NK035L	PT035M	SK035L	UH035M
BA035S	GA035L	HG035S	KT035M	NK035N	PT035N	SK035N	UH035N
BG035D	GA035M	HH035E	KT035N	NR035E	PT035S	SK035R	UH035R
BG035E	GA035N	HH035F	KT035S	NR035S	PU035E	SL035E	UH035S
BG035F	GA035S	HH035L	MG035D	NT035E	PU035L	SL035L	UJ035D
BG035L	GG035E	HH035M	MG035E	NT035L	PU035M	SR035E	UJ035E
BG035M	GG035L	HH035N	MG035F	NT035M	PU035N	SR035S	UJ035F
BG035N	GG035M	HH035R	MG035L	NT035N	PU035S	ST035E	UJ035L
BG035R	GG035N	HH035S	MG035M	NT035S	SA035E	ST035F	UJ035M
BG035S	GG035S	HJ035D	MG035N	NU035E	SA035F	ST035L	UJ035N
BH035E	GH035E	HJ035E	MG035R	NU035L	SA035L	ST035M	UJ035R
BH035F	GH035L	HJ035F	MG035S	NU035M	SA035M	ST035N	UJ035S
BH035L	GH035M	HJ035L	MJ035D	NU035N	SA035N	ST035R	UK035E
BH035M	GH035N	HJ035M	MJ035E	NU035S	SA035R	ST035S	UK035F
BH035N	GH035S	HJ035N	MJ035F	PA035E	SA035S	SU035E	UK035L
BH035R	GJ035E	HJ035R	MJ035L	PA035L	SG035D	SU035F	UK035N
BH035S	GJ035L	HJ035S	MJ035M	PA035M	SG035E	SU035L	UK035R
BJ035D	GJ035M	HK035E	MJ035N	PA035N	SG035F	SU035M	UL035E
BJ035E	GJ035N	HK035F	MJ035R	PA035S	SG035L	SU035N	UL035L
BJ035F	GJ035S	HK035L	MJ035S	PG035E	SG035M	SU035P	UR035E
BJ035L	GK035E	HK035N	NA035E	PG035L	SG035N	SU035R	UR035S
BJ035M	GK035L	HK035R	NA035L	PG035M	SG035R	SU035S	UT035E
BJ035N	GK035N	HL035E	NA035M	PG035N	SG035S	UA035E	UT035F
BJ035R	GU035E	HL035L	NA035N	PG035S	SH035E	UA035F	UT035L
BJ035S	GU035L	HR035E	NA035S	PH035E	SH035F	UA035L	UT035M
BK035E	GU035M	HR035S	NG035E	PH035L	SH035L	UA035M	UT035N
BK035F	GU035N	HT035E	NG035L	PH035M	SH035M	UA035N	UT035R
BK035L	GU035S	HT035F	NG035M	PH035N	SH035N	UA035R	UT035S
BK035N	HA035E	HT035L	NG035N	PH035S	SH035R	UA035S	UU035E
BK035R	HA035F	HT035M	NG035S	PJ035E	SH035S	UG035D	UU035F
BL035E	HA035L	HT035N	NH035E	PJ035L	SJ035D	UG035E	UU035L

Table continues...

35 Series (16 Kg)							
BL035L	HA035M	HT035R	NH035L	PJ035M	SJ035E	UG035F	UU035M
BR035E	HA035N	HT035S	NH035M	PJ035N	SJ035F	UG035L	UU035N
BR035S	HA035R	HU035E	NH035N	PJ035S	SJ035L	UG035M	UU035R
BU035E	HA035S	HU035F	NH035S	PK035E	SJ035M	UG035N	UU035S
BU035F	HG035D	HU035L	NJ035E	PK035L			
RT035E-IA	RT035F-IA	RT035L-IA	RT035N-IA	RT035R-IA	RT035S-IA	RT035T-IA	
RT035E-TA	RT035F-TA	RT035L-TA	RT035N-TA	RT035R-TA	RT035S-TA	RT035T-TA	

T45 Series (20/20 Kg) * Only available in gas							
BAT45L	BUT45L	HGT45D	HUT45L	NHT45N	PKT45N	SJT45R	UHT45L
BAT45N	BUT45N	HGT45L	HUT45N	NJT45L	PTT45L	SKT45L	UHT45N
BAT45R	BUT45R	HGT45N	HUT45R	NJT45N	PTT45N	SKT45N	UHT45R
BGT45D	GAT45L	HGT45R	KTT45L	NKT45L	PUT45L	SKT45R	UJT45D
BGT45L	GAT45N	HHT45L	KTT45N	NKT45N	PUT45N	SLT45L	UJT45L
BGT45N	GGT45L	HHT45N	MGT45D	NTT45L	SAT45L	STT45L	UJT45N
BGT45R	GGT45N	HHT45R	MGT45L	NTT45N	SAT45N	STT45N	UJT45R
BHT45L	GHT45L	HJT45D	MGT45N	NUT45L	SAT45R	STT45R	UKT45L
BHT45N	GHT45N	HJT45L	MGT45R	NUT45N	SGT45D	SUT45L	UKT45N
BHT45R	GJT45L	HJT45N	MJT45D	PAT45L	SGT45L	SUT45N	UKT45R
BJT45D	GJT45N	HJT45R	MJT45L	PAT45N	SGT45N	SUT45R	ULT45L
BJT45L	GKT45L	HKT45L	MJT45N	PGT45L	SGT45R	UAT45L	UTT45L
BJT45N	GKT45N	HKT45N	MJT45R	PGT45N	SHT45L	UAT45N	UTT45N
BJT45R	GUT45L	HKT45R	NAT45L	PHT45L	SHT45N	UAT45R	UTT45R
BKT45L	GUT45N	HLT45L	NAT45N	PHT45N	SHT45R	UGT45D	UUT45L
BKT45N	HAT45L	HTT45L	NGT45L	PJT45L	SJT45D	UGT45L	UUT45N
BKT45R	HAT45N	HTT45N	NGT45N	PJT45N	SJT45L	UGT45N	UUT45R
BLT45L	HAT45R	HTT45R	NHT45L	PKT45L	SJT45N	UGT45R	
RTT45L-IA	RTT45N-IA	RTT45R-IA					
RTT45L-TA	RTT45N-TA	RTT45R-TA					

55 Series (24 Kg) * Only available in gas and electric							
BA055E	BR055E	HG055D	HT055R	NH055N	PR055E	SK055E	UH055E
BA055F	BU055E	HG055E	HU055E	NJ055E	PT055E	SK055F	UH055F
BA055L	BU055F	HG055F	HU055F	NJ055L	PT055L	SK055L	UH055L
BA055N	BU055L	HG055L	HU055L	NJ055N	PT055N	SK055N	UH055N
BA055R	BU055N	HG055N	HU055N	NK055E	PU055E	SK055R	UH055R
BG055D	BU055R	HG055R	HU055R	NK055L	PU055L	SL055E	UJ055D
BG055E	GA055E	HH055E	KT055E	NK055N	PU055N	SL055L	UJ055E
BG055F	GA055L	HH055F	KT055L	NR055E	SA055E	SR055E	UJ055F
BG055L	GA055N	HH055L	KT055N	NT055E	SA055F	ST055E	UJ055L
BG055N	GG055E	HH055N	MG055D	NT055L	SA055L	ST055F	UJ055N
BG055R	GG055L	HH055R	MG055E	NT055N	SA055N	ST055L	UJ055R
BH055E	GG055N	HJ055D	MG055F	NU055E	SA055R	ST055N	UK055E
BH055F	GH055E	HJ055E	MG055L	NU055L	SG055D	ST055R	UK055F
BH055L	GH055L	HJ055F	MG055N	NU055N	SG055E	SU055E	UK055L
BH055N	GH055N	HJ055L	MG055R	PA055E	SG055F	SU055F	UK055N
BH055R	GJ055E	HJ055N	MJ055D	PA055L	SG055L	SU055L	UK055R
BJ055D	GJ055L	HJ055R	MJ055E	PA055N	SG055N	SU055N	UL055E
BJ055E	GJ055N	HK055E	MJ055F	PG055E	SG055R	SU055R	UL055L
BJ055F	GK055E	HK055F	MJ055L	PG055L	SH055E	UA055E	UR055E
BJ055L	GK055L	HK055L	MJ055N	PG055N	SH055F	UA055F	UT055E
BJ055N	GK055N	HK055N	MJ055R	PH055E	SH055L	UA055L	UT055F
BJ055R	GU055E	HK055R	NA055E	PH055L	SH055N	UA055N	UT055L
BK055E	GU055L	HL055E	NA055L	PH055N	SH055R	UA055R	UT055N
BK055F	GU055N	HL055L	NA055N	PJ055E	SJ055D	UG055D	UT055R
BK055L	HA055E	HR055E	NG055E	PJ055L	SJ055E	UG055E	UU055E
BK055N	HA055F	HT055E	NG055L	PJ055N	SJ055F	UG055F	UU055F
BK055R	HA055L	HT055F	NG055N	PK055E	SJ055L	UG055L	UU055L
BL055E	HA055N	HT055L	NH055E	PK055L	SJ055N	UG055N	UU055N
BL055L	HA055R	HT055N	NH055L	PK055N	SJ055R	UG055R	UU055R
RT055E-IA	RT055F-IA	RT055L-IA	RT055N-IA	RT055R-IA			
RT055E-TA	RT055F-TA	RT055L-TA	RT055N-TA	RT055R-TA			

Heater Digit (Position 6)
D - Liquid Petroleum (L.P.) Gas, Japan
E - Electric
F - Reduced Electric (Eco Line)
L - L.P. Gas
M - Medium Electric
N - Natural Gas
P - Low Electric
R - Reduced Gas, Natural Gas (Eco Line)
S - Steam

Contact Information

If service is required, contact the nearest Factory Authorized Service Center.

If you are unable to locate an authorized service center or are unsatisfied with the service performed on your unit, contact the source from which you purchased your unit.

When calling or writing about your unit, PLEASE GIVE THE MODEL AND SERIAL NUMBERS. The model and serial numbers are located on the serial plate. The serial plate will be in the location shown in *Figure 1*.

Date Purchased _____

Model Number _____

Serial Number _____

Please include a copy of your bill of sale and any service receipts you have.

	<h2>WARNING</h2>
<p>To reduce the risk of serious injury or death, DO NOT repair or replace any part of the unit or attempt any servicing unless specifically recommended in the user-maintenance instructions or in published user-repair instructions that you understand and have the skills to carry out.</p>	
<small>W329</small>	

If replacement parts are required, contact the source from where you purchased your unit.

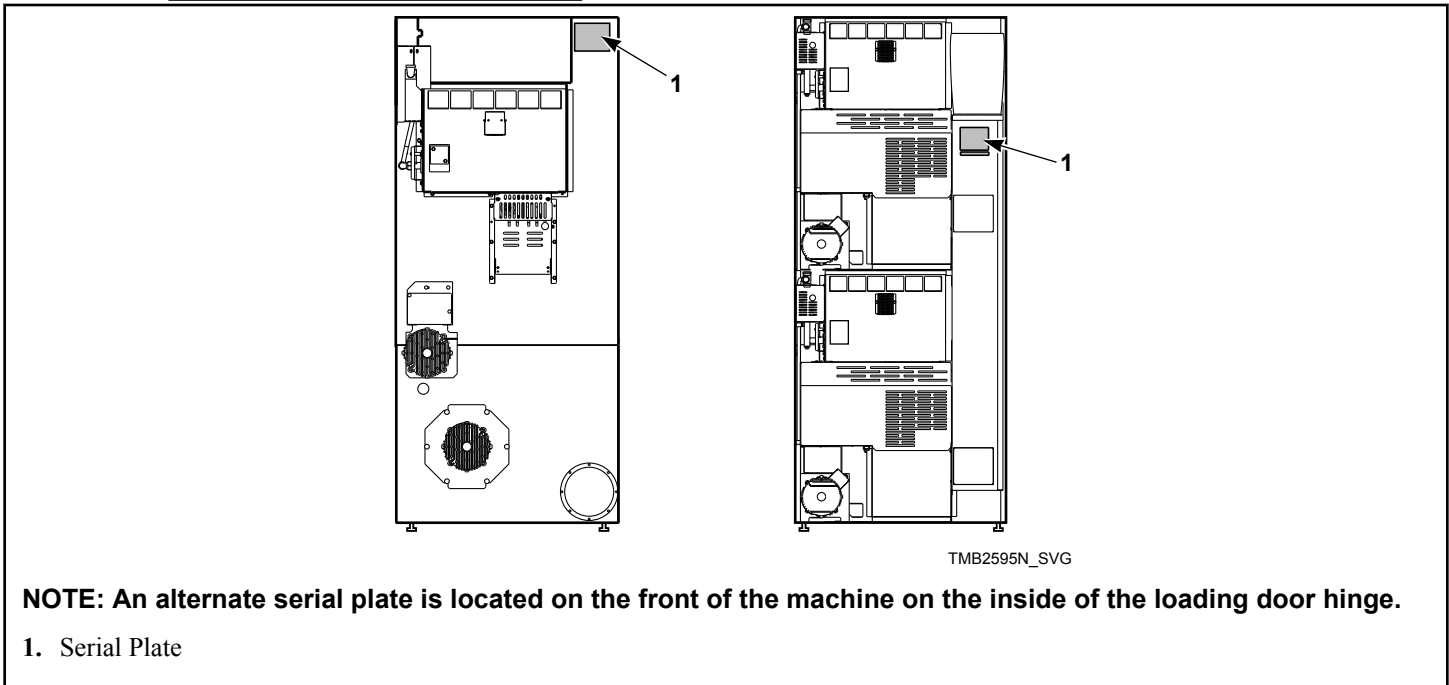

Figure 1

Specifications and Dimensions

Specifications and Dimensions

Refer to machine serial plate for additional specifications.

Specifications	025 Series	030 Series	035 Series	055 Series
Weights and Shipping Information				
Net Weight (approximate): Pounds [kg]	Gas and Steam 300 [135] Electric 310 [140]	Gas and Steam 320 [145] Electric 330 [150]	Gas and Steam 340 [155] Electric 350 [160]	Gas 430 [195] Electric 440 [200]
Standard Packaging Weight: Pounds [kg]	Gas and Steam 320 [145] Electric 330 [150]	Gas and Steam 340 [155] Electric 350 [160]	Gas and Steam 360 [165] Electric 370 [170]	Gas 470 [215] Electric 480 [220]
Slat Crate Packaging Weight: Pounds [kg]	Gas and Steam 450 [205] Electric 460 [210]	Gas and Steam 470 [215] Electric 480 [220]	Gas and Steam 490 [220] Electric 500 [230]	Gas 650 [295] Electric 660 [300]
Standard Packaging Shipping Dimensions: Inch [mm]	30.0 x 43.0 x 67.6 [760 x 1,090 x 1,720]	30.0 x 49.0 x 67.6 [760 x 1,240 x 1,720]	33.0 x 49.0 x 67.6 [840 x 1,240 x 1,720]	35.5 x 57.0 x 70.5 [900 x 1,450 x 1,790]
Standard Packaging Shipping Volume: ft ³ [m ³]	50 [1.4]	58 [1.6]	63 [1.8]	83 [2.4]
Slat Crate Packaging Shipping Dimensions: Inch [mm]	34.5 x 46.0 x 87.0 [880 x 1,170 x 2,210]	34.5 x 52.0 x 87.0 [880 x 1,320 x 2,210]	37.5 x 52.0 x 87.0 [950 x 1,320 x 2,210]	40.0 x 60.0 x 87.0 [1,020 x 1,520 x 2,210]
Slat Crate Packaging Shipping Volume: ft ³ [m ³]	80 [2.3]	90 [2.5]	98 [2.8]	121 [3.4]
Cylinder Size				
Cylinder Size: Inch [mm]	26.5 x 24.0 [673 x 610]	26.5 x 30.0 [673 x 762]	30.0 x 30.0 [762 x 762]	33.0 x 35.0 [838 x 889]
Cylinder Capacity (dry weight): Pounds [kg]	25 [11]	30 [13]	35 [16]	55 [24]
Cylinder Volume: feet ³ [Liter]	7.7 [220]	9.6 [270]	12.3 [350]	17.3 [490]
Operational Information				

Table 1 continues...

Specifications	025 Series	030 Series	035 Series	055 Series
Drive Motor: Horsepower [kW]	0.3 [0.2]	0.3 [0.2]	0.3 [0.2]	0.5 [0.4]
Fan Motor: Horsepower [kW]	0.5 [0.4]	0.5 [0.4]	0.5 [0.4]	0.5 [0.4]
Air Outlet Diameter: Inch [mm]	Standard Line 6.0 [150] Eco Line 4.0 [100]	Standard Line 6.0 [150] Eco Line 6.0 [150]	Standard Line 8.0 [200] Eco Line 6.0 [150]	Standard Line 8.0 [200] Eco Line 8.0 [200]
Maximum Airflow: C.F.M. [l/sec]	Standard Line 500 [240] Eco Line 300 [140]	Standard Line 500 [240] Eco Line 500 [240]	Standard Line 600 [280] Eco Line 550 [260]	Standard Line 700 [330] Eco Line 700 [330]
Maximum Static Back Pressure: Inch W.C. [mbar, kPa]	Standard Line 0.80 [2.0, 0.20] Eco Line 1.4 [3.5, 0.35]	Standard Line 0.80 [2.0, 0.20] Eco Line 0.80 [2.0, 0.20]	Standard Line 0.60 [1.5, 0.15] Eco Line 0.90 [2.2, 0.22]	Standard Line 0.60 [1.5, 0.15] Eco Line 0.60 [1.5, 0.15]
Minimum Static Back Pressure: Inch W.C. [mbar, kPa]	0.0 [0.0, 0.0]	0.0 [0.0, 0.0]	0.0 [0.0, 0.0]	0.0 [0.0, 0.0]
Heat dissipation of surface area exposed to conditioned air: Btu/ft ² [Joules/m ²]	60 [680,000]	60 [680,000]	60 [680,000]	60 [680,000]
Noise level measured during operation at operator position of 3.3 feet [1 meter] in front of machine and 5.2 feet [1.6 meters] from floor	59 dBA	59 dBA	61 dBA	61 dBA
Door Opening Information				
Door Opening Diameter: Inch [mm]	22.7 [576]	22.7 [576]	22.7 [576]	26.9 [684]
Door Hinge Side	Right (Reversible)	Right (Reversible)	Right (Reversible)	Right (Reversible)
Door Maximum Open Angle: Degrees	180	180	180	180
Gas Models				

Table 1 *continues...*

Specifications	025 Series	030 Series	035 Series	055 Series
Gas Connection	1/2 NPT	1/2 NPT	1/2 NPT	1/2 NPT
Gas Burner Rating: BTU/hr. [kW, Mj/hr.]	Standard Line 64,000 [18.8, 67.5] Eco Line 52,500 [15.4, 55.4]	Standard Line 73,000 [21.4, 77.0] Eco Line 55,000 [16.1, 58.0]	Standard Line 90,000 [26.4, 95.0] Eco Line 64,000 [18.8, 67.5]	Standard Line 112,000 [32.8, 118] Eco Line 105,000 [30.8, 111]
Electric Models				
Heating Element Rating: Kilowatts	Standard Line - 12 Eco Line - 9	Standard Line - 21 Eco Line - 12	Standard Line - 24 Medium - 18 Eco Line - 12 Low - 9	Standard Line - 27 Eco Line - 18
Steam Models				
Steam Connection (Inlet and Outlet)	3/4 NPT	3/4 NPT	3/4 NPT	Not Applicable
Steam Coil Rating at 100 psig: BTU/hr. [kg/hr.] (recommended operating pressure 80-100 psig)	83,500 [39.5]	83,500 [39.5]	103,400 [49.0]	Not Applicable

Table 1

NOTE: All IEC machines are shipped with an adapter to convert the gas connection threads to BSPT (from NPT).

Specifications	T30 Series	T45 Series
Weights and Shipping Information		
Net Weight (approximate): Pounds [kg]	Gas 570 [260] Steam 610 [275] Electric 630 [285]	670 [300]
Standard Packaging Weight: Pounds [kg]	Gas 600 [270] Steam 640 [290] Electric 660 [300]	710 [320]

Table 2 *continues...*

Specifications and Dimensions

Specifications	T30 Series	T45 Series
Slat Crate Packaging Weight: Pounds [kg]	Gas 730 [330] Steam 770 [350] Electric 790 [360]	890 [400]
Standard Packaging Shipping Dimensions: Inch [mm]	32.5 x 47.0 x 79.9 [830 x 1,190 x 2,030]	35.5 x 54.0 x 84.9 [900 x 1,370 x 2,160]
Standard Packaging Shipping Volume: ft ³ [m ³]	82 [2.3]	94 [2.7]
Slat Crate Packaging Shipping Dimensions: Inch [mm]	35.5 x 50.0 x 87.0 [900 x 1,270 x 2,210]	40.0 x 60.0 x 87.0 [1,020 x 1,520 x 2,210]
Slat Crate Packaging Shipping Volume: ft ³ [m ³]	89 [2.5]	121 [3.4]
Cylinder Information		
Cylinder Size: Inch [mm]	30.0 x 26.0 [762 x 660]	33.0 x 30.0 [838 x 762]
Cylinder Capacity (dry weight): Pounds [kg]	2 x 30 [2 x 13]	2 x 45 [2 x 20]
Cylinder Volume: feet ³ [Liter]	2 x 10.6 [2 x 300]	2 x 14.8 [2 x 420]
Operational Information		
Drive Motor (per pocket): Horsepower [kW]	0.3 [0.2]	0.5 [0.4]
Fan Motor (per pocket): Horsepower [kW]	0.5 [0.4]	0.5 [0.4]
Air Outlet Diameter: Inch [mm]	Standard Line (elliptical) 8.0 [200] Eco Line (round) 6.0 [150]	Standard Line 10.0 [250] Eco Line 10.0 [250]
Maximum Airflow (total machine): C.F.M. [l/sec]	Standard Line 800 [380] Eco Line 660 [310]	Standard Line 1,200 [570] Eco Line 1,200 [570]

Table 2 continues...

Specifications	T30 Series	T45 Series
Maximum Static Back Pressure (total machine): Inch W.C. [mbar, kPa]	0.90 [2.2, 0.22]	0.90 [2.2, 0.22]
Minimum Static Back Pressure (total machine): Inch W.C. [mbar, kPa]	0.0 [0.0, 0.0]	0.0 [0.0, 0.0]
Heat dissipation of surface area exposed to conditioned air: Btu/ft ² [Joules/m ²]	60 [680,000]	60 [680,000]
Noise level measured during operation at operator position of 3.3 feet [1 meter] in front of machine and 5.2 feet [1.6 meters] from floor (total machine)	63 dBA	65 dBA
Door Opening Information		
Door Opening Diameter: Inch [mm]	22.7 [576]	26.9 [684]
Door Hinge Side	Right	Right
Door Maximum Open Angle: Degrees	180	180
Gas Models		
Gas Connection	1/2 NPT	1/2 NPT
Gas Burner Rating (per pocket): BTU/hr. [kW, Mj/hr.]	Standard Line 73,000 [21.4, 77.0] Eco Line 55,000 [16.1, 58.0]	Standard Line 95,000 [27.8, 100] Eco Line 80,000 [23.4, 84.4]
Gas Burner Rating (total machine): BTU/hr. [kW, Mj/hr.]	Standard Line 146,000 [42.8, 154] Eco Line 110,000 [32.2, 116]	Standard Line 190,000 [55.6, 200] Eco Line 160,000 [46.8, 169]
Electric Models		
Heating Element Rating (per pocket): Kilowatts	Standard Line - 21 Eco Line - 12	Not Applicable
Steam Models		
Steam Connection (Inlet and Outlet)	3/4 NPT	Not Applicable

Table 2 *continues...*

Specifications	T30 Series	T45 Series
Steam Coil Rating at 100 psig (per pocket): BTU/hr. [kg/hr.] (recommended operating pressure 80-100 psig)	85,400 [40.4]	Not Applicable
Steam Coil Rating at 100 psig (total machine): BTU/hr. [kg/hr.] (recommended operating pressure 80-100 psig)	170,800 [80.8]	Not Applicable

Table 2

NOTE: All IEC machines are shipped with an adapter to convert the gas connection threads to BSPT (from NPT).

Cabinet Dimensions – 025, 030, 035 and 055 Series

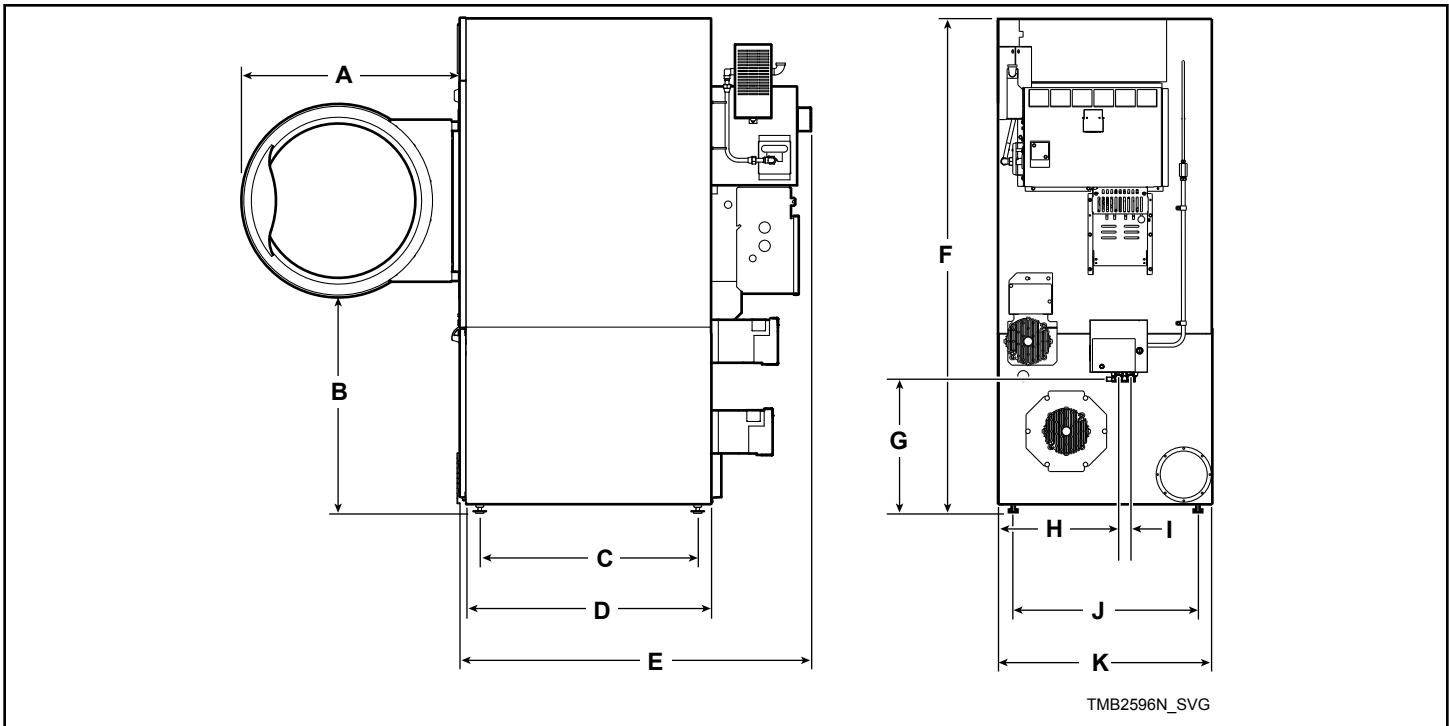

Machine Dimensions, in. [mm]					
Models	A	B	C	D	E
025 Series	26.3 [670]	27.5 [700]	22.4 [570]	25.8 [655]	39.4 [1,000]
030 Series	26.3 [670]	27.5 [700]	28.4 [720]	31.8 [810]	45.5 [1,155]

Table 3 continues...

Machine Dimensions, in. [mm]					
Models	A	B	C	D	E
035 Series	28.0 [710]	27.5 [700]	28.4 [720]	31.8 [810]	45.5 [1,155]
055 Series	31.9 [810]	26.9 [680]	33.4 [850]	36.8 [935]	53.1 [1,350]

Table 3

Models	F	G*	H*	I*	J	K
025 Series	63.9 [1,625]	16.5 [420]	15.4 [390]	1.6 [40]	24.6 [625]	27.9 [710]
030 Series	63.9 [1,625]	16.5 [420]	15.4 [390]	1.6 [40]	24.6 [625]	27.9 [710]
035 Series	63.9 [1,625]	16.5 [420]	19.6 [500]	1.6 [40]	27.4 [695]	31.5 [800]
055 Series	66.7 [1,700]	17.75 [450]	18.7 [475]	1.6 [40]	30.5 [775]	34.5 [875]

* Fire suppression system optional - may not be on machine.

NOTE: Facia panels available to increase height of models to 72.25 inches [1,840 mm] and 76.25 inches [1,940 mm].

Cabinet Dimensions – T30 and T45 Series

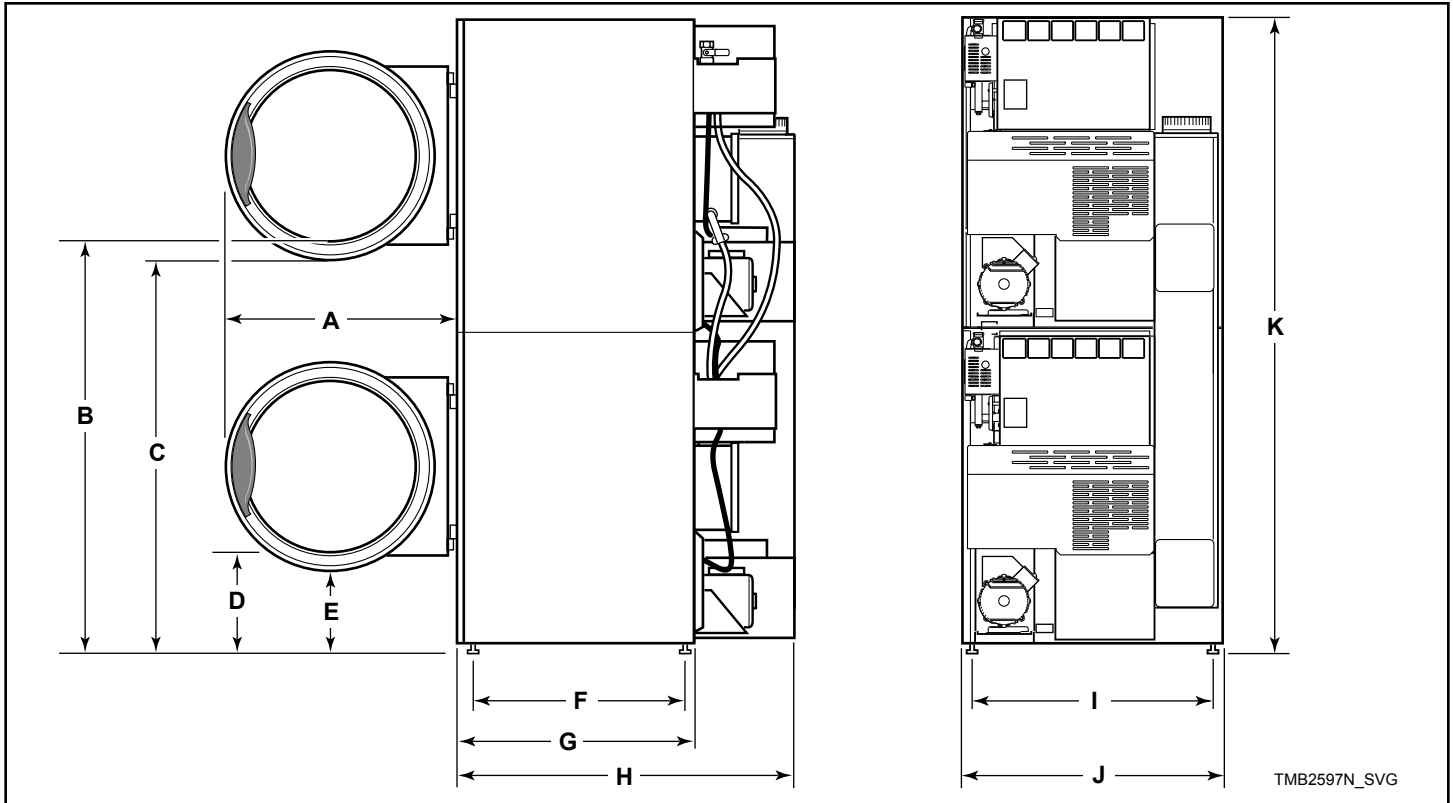

Machine Dimensions, in. [mm]					
Models	A	B	C	D	E
T30 Series	28.0 [710]	49.0 [1,245]	48.3 [1,225]	11.4 [290]	10.7 [270]
T45 Series	31.9 [810]	50.4 [1,280]	49.3 [1,250]	10.3 [260]	9.3 [235]

Table 4

Models	F	G	H	I	J	K
T30 Series	25.0 [635]	28.7 [730]	42.8 [1,090]	27.4 [695]	31.5 [800]	76.3 [1,940]
T45 Series	29.0 [735]	32.7 [830]	48.6 [1,235]	30.4 [770]	34.5 [875]	81.3 [2,065]

NOTE: To meet Americans with Disabilities Act (ADA) compliance, install a 4 inch [100 mm] riser on T30 models only.

Exhaust Outlet Locations – 025, 030, 035 and 055 Series

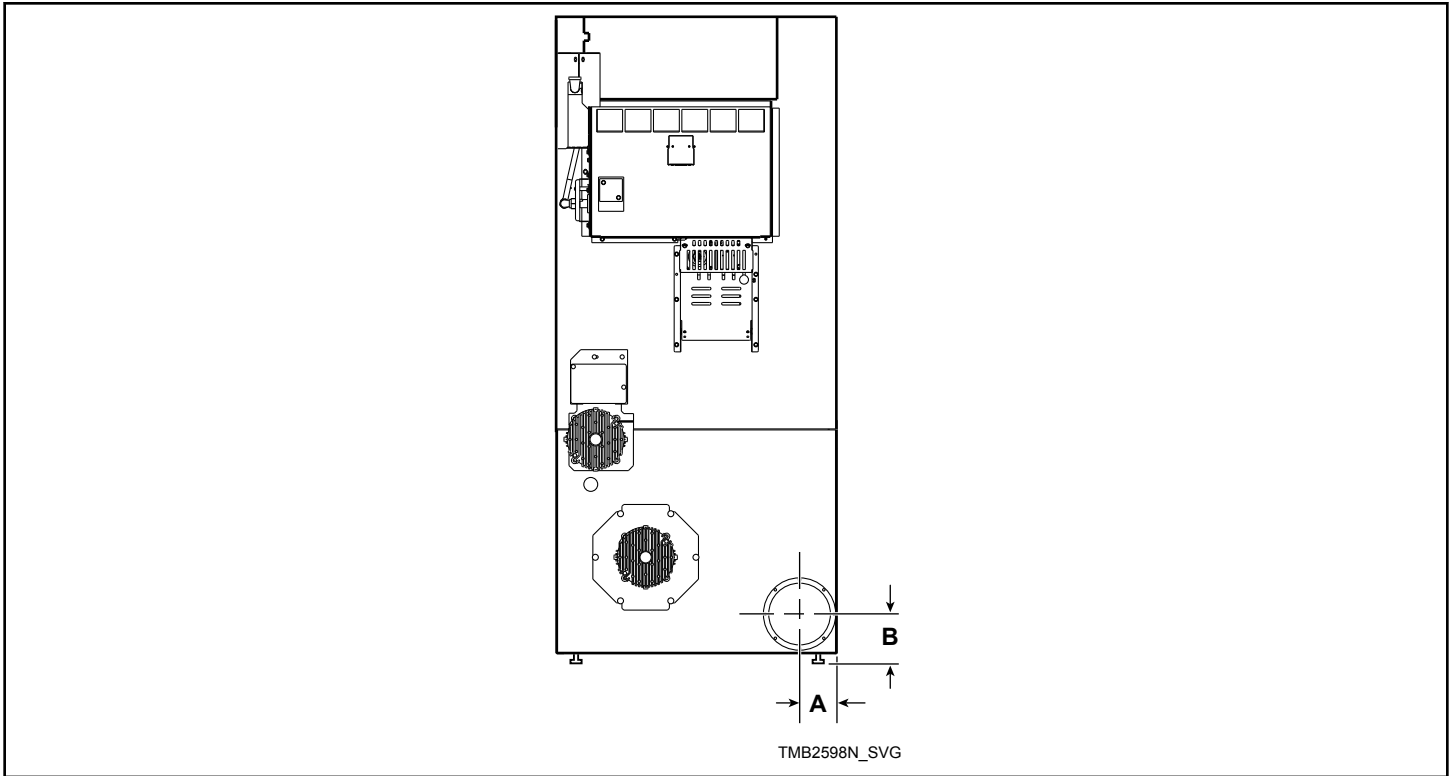

Models	Rear Exhaust Dimensions, in. [mm]			
	Diameter			
025 Series	Standard Line 6.0 [150]	Eco Line 4.0 [100]	3.9 [100]	4.6 [115]
030 Series	Standard Line 6.0 [150]	Eco Line 6.0 [150]	3.9 [100]	4.6 [115]
035 Series	Standard Line 8.0 [200]	Eco Line 6.0 [150]	4.9 [125]	5.6 [145]
055 Series	Standard Line 8.0 [200]	Eco Line 8.0 [200]	4.9 [125]	5.6 [145]

Table 5

Exhaust Outlet Locations – T30 and T45 Series

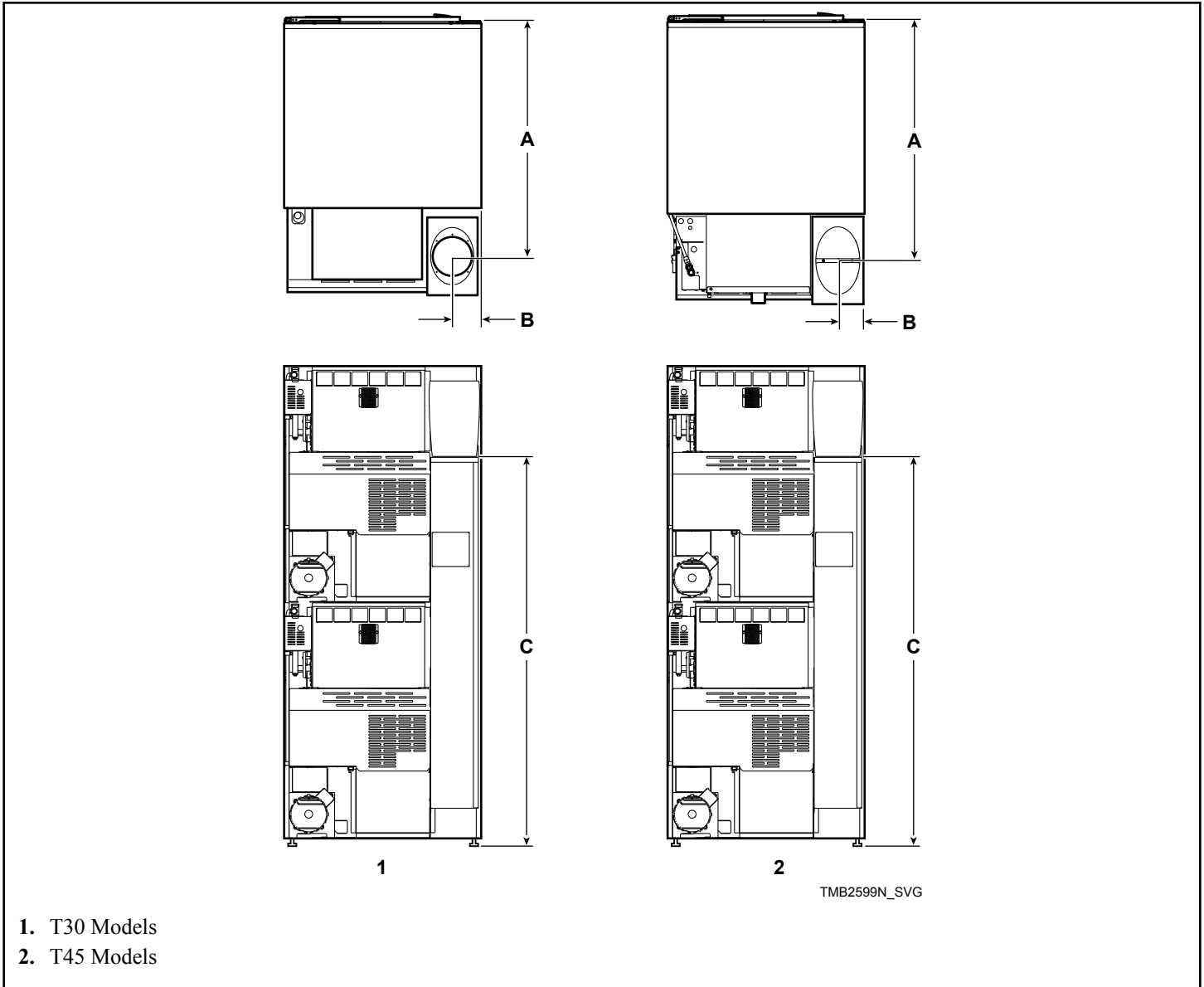

Models	Rear Exhaust Dimensions, in. [mm]				
	Diameter		A	B	C
T30 Series	Standard Line Elliptical Fits 8.0 [200]	Eco Line Round Fits 6.0 [150]	36.5 [930]	4.3 [110]	62.4 [1,585]

Table 6 continues...

Models	Rear Exhaust Dimensions, in. [mm]				
	Diameter		A	B	C
T45 Series	Standard Line Elliptical Fits 10.0 [250]	Eco Line Elliptical Fits 10.0 [250]	40.9 [1,040]	4.8 [120]	66.0 [1,675]

Table 6

Gas Connection Locations – 025, 030, 035 and 055 Series

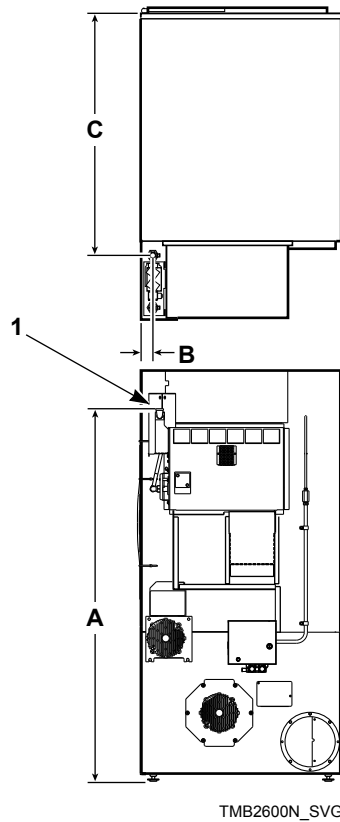

1. 1/2 NPT

Models	Gas Connection, in. [mm]		
	A	B	C
025 Series	58.0 [1,475]*	2.0 [50]	35.5 [900]
030 Series	58.0 [1,475]*	2.0 [50]	41.5 [1,055]
035 Series	58.0 [1,475]*	3.0 [75]	41.5 [1,055]
055 Series	55.0 [1,400]	1.6 [40]	49.0 [1,245]*
* IEC models add 0.5 [12]			

Table 7

Gas Connection Locations – T30 and T45 Series

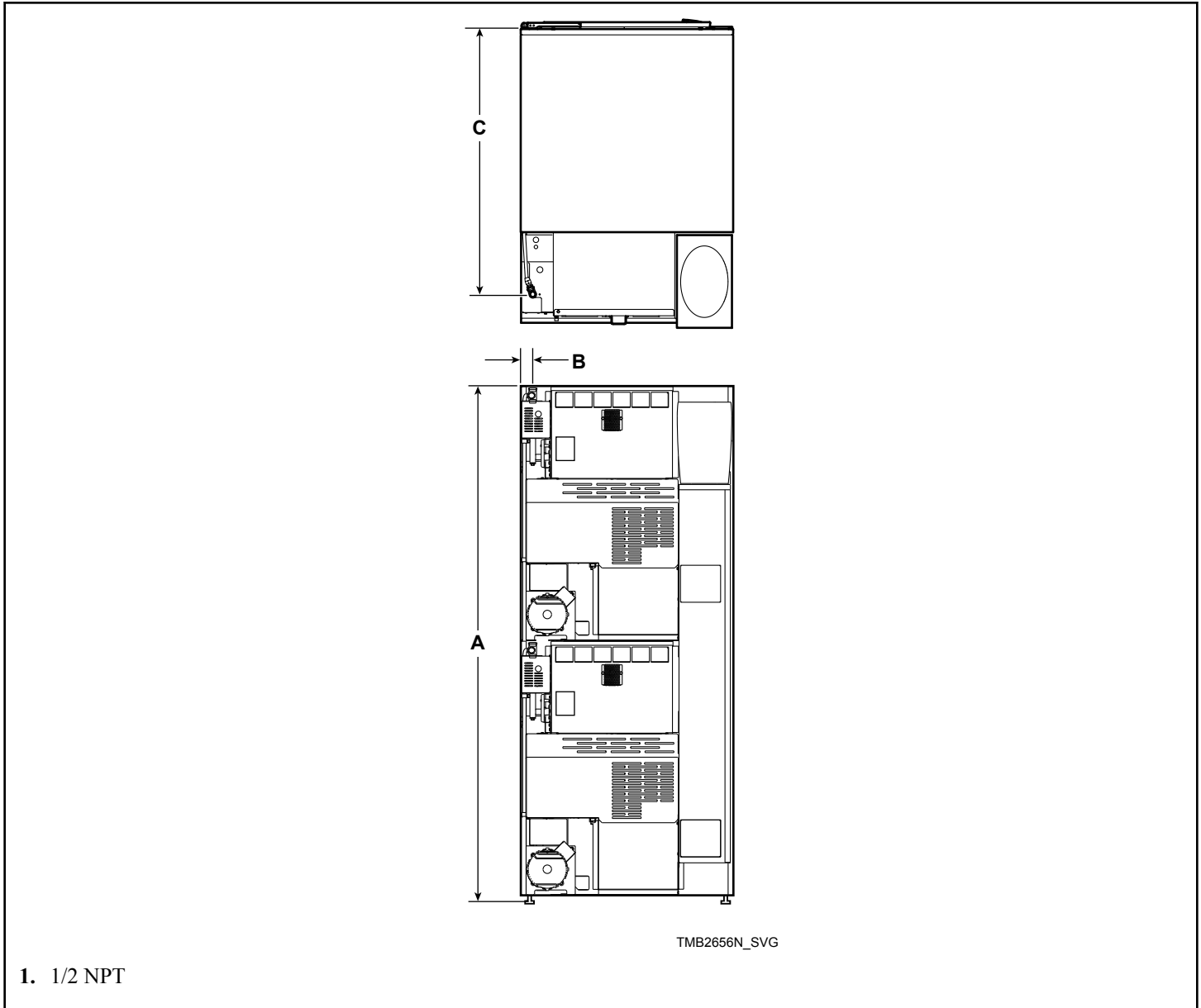

Models	Gas Connection, in. [mm]		
	A	B	C
T30 Series	75.5 [1,920]	1.7 [45]	36.8 [935]
T45 Series	79.0 [2,005]	4.1 [105]	42.9 [1,090]

Table 8

Electrical Connection Locations – 025, 030, 035 and 055 Series

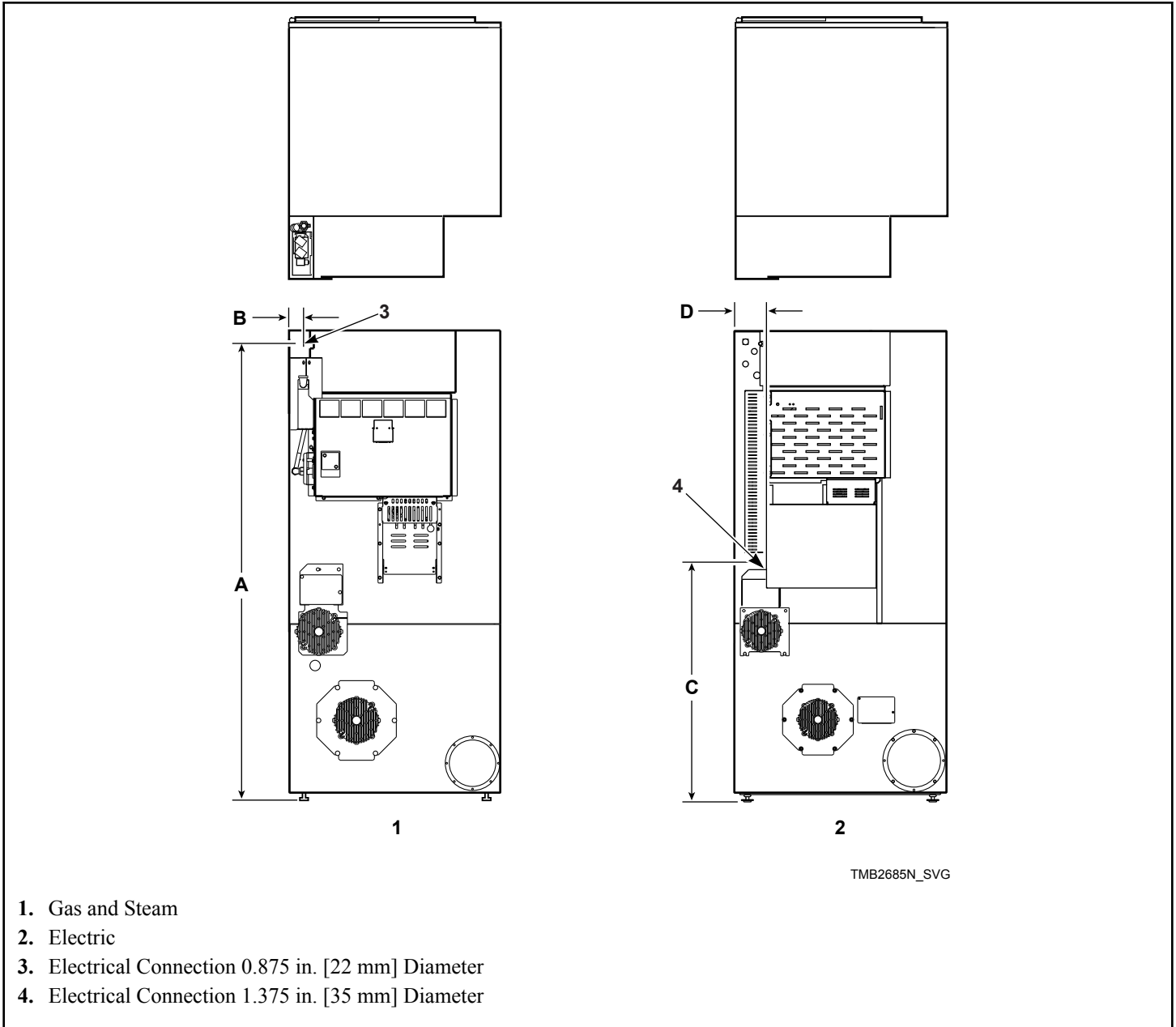

Models	Electrical Service Dimensions, in. [mm]			
	Gas and Steam Models		Electric Models	
	A	B	C	D
025/030 Series	62.3 [1,580]	1.4 [35]	29.6 [750]	3.3 [80]
035 Series	62.3 [1,580]	1.8 [45]	29.6 [750]	5.0 [130]

Table 9 continues...

Models	Electrical Service Dimensions, in. [mm]			
	Gas and Steam Models		Electric Models	
	A	B	C	D
055 Series	64.6 [1,640]	1.8 [45]	30.5 [775]	6.6 [170]

Table 9

Electrical Connection Locations – T30 and T45 Series

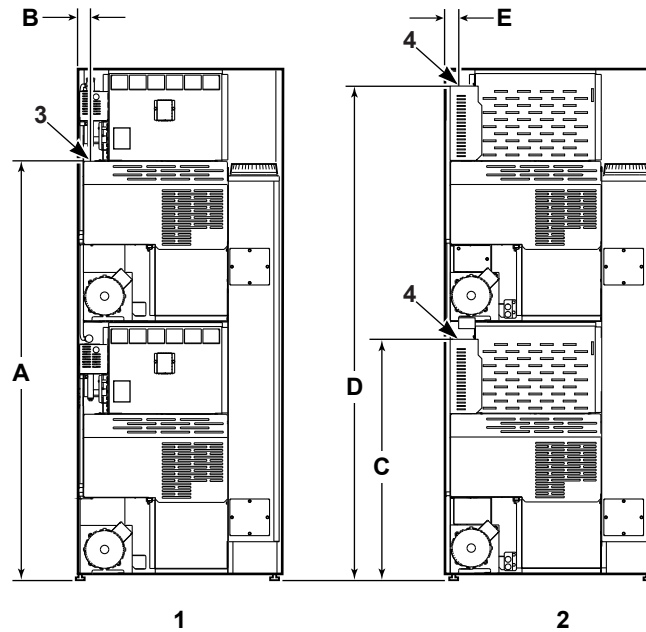

TMB2603N_SVG

1. Gas and Steam
2. Electric
3. Electrical Connection 0.875 in. [22 mm] Diameter
4. Electrical Connection 1.625 in. [40 mm] Diameter

Models	Electric Service Dimensions, in. [mm]				
	Gas and Steam Models		Electric Models		
	A	B	C	D	E
T30 Series	62.0 [1,575]	1.5 [40]	35.7 [905]	73.2 [1,860]	2.3 [60]
T45 Series	65.6 [1,665]	2.3 [60]	Not Applicable	Not Applicable	Not Applicable

Table 10

Steam Connection Locations – 025, 030 and 035 Series

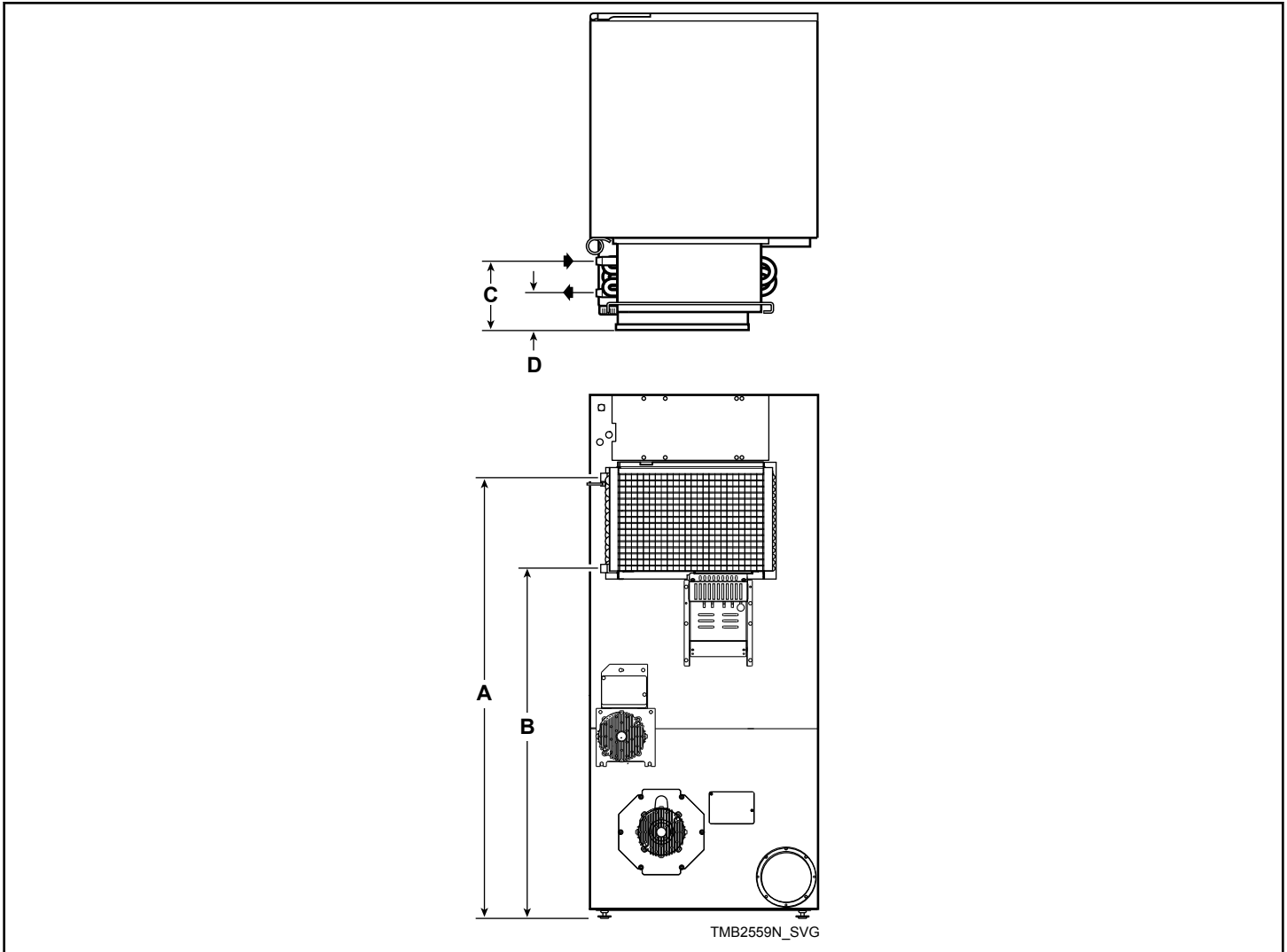

Models	Inlet Dimensions, in. [mm]		Outlet Dimensions, in. [mm]	
	A	C	B	D
025/030 Series	53.6 [1,360]	5.3 [135]	42.3 [1,075]	1.4 [35]
035 Series	53.6 [1,360]	5.3 [135]	42.3 [1,075]	1.4 [35]

Table 11

NOTE: All connections use 3/4 NPT pipe.

Steam Connection Locations – T30 Series

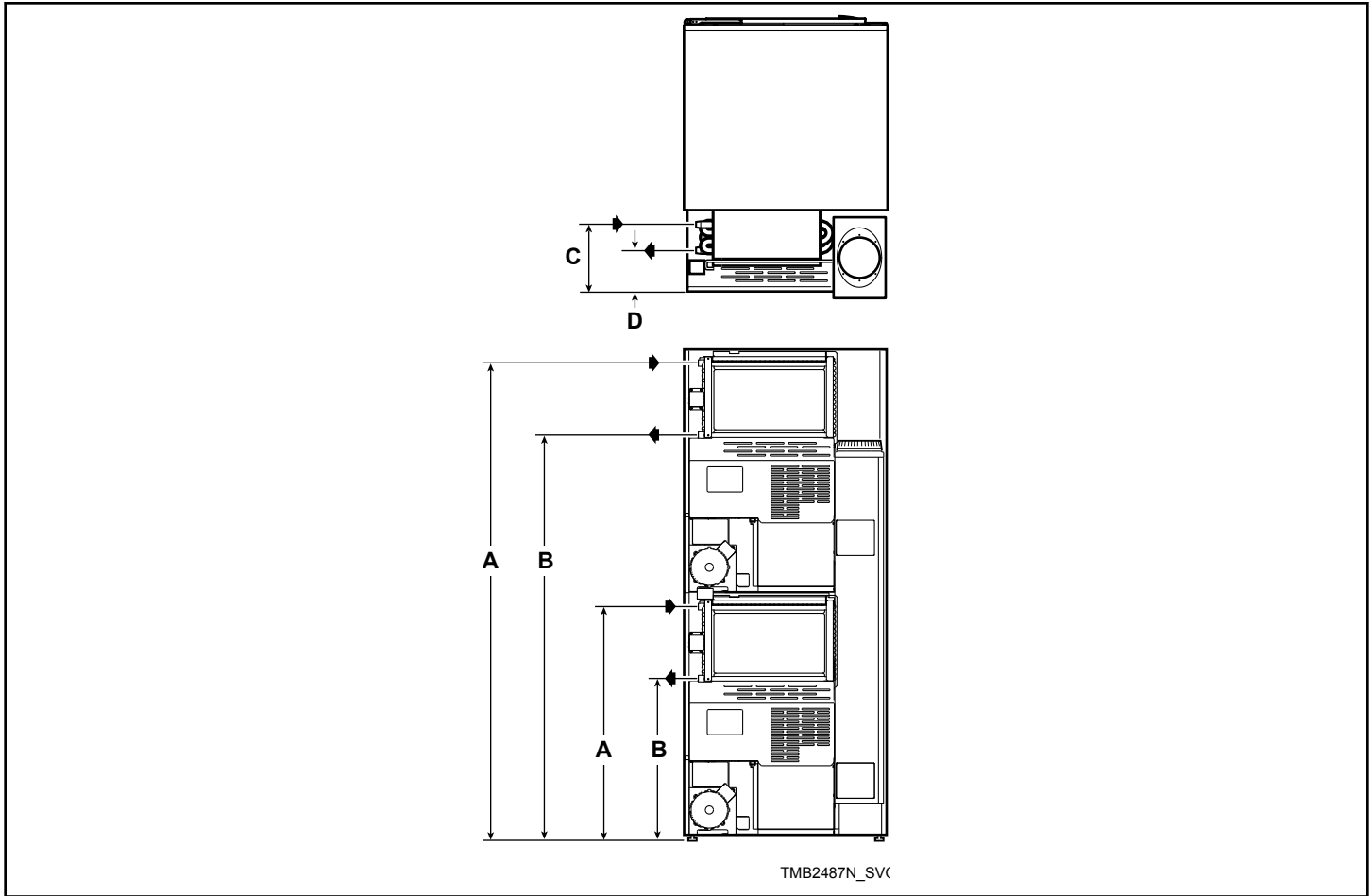

Models	Inlet Dimensions, in. [mm]		Outlet Dimensions, in. [mm]	
	A	C	B	D
T30 Series (Upper)	74.0 [1,880]	6.3 [160]	62.8 [1,595]	2.4 [60]
T30 Series (Lower)	36.4 [925]	10.1 [255]	25.5 [650]	6.2 [160]

Table 12

NOTE: All connections use 3/4 NPT pipe.

Installation

Pre-Installation Inspection

Upon delivery, visually inspect the crate, carton and parts for any visible shipping damage. If the crate, carton, or cover is damaged or signs of possible damage are evident, have the carrier note the condition on the shipping papers before the shipping receipt is signed, or advise the carrier of the condition as soon as it is discovered.

Remove the crate and protective cover as soon as possible and check the items listed on the packing list. Advise the carrier of any damaged or missing articles as soon as possible. A written claim should be filed with the carrier immediately if articles are damaged or missing.

IMPORTANT: Remove the yellow shipping wire tie securing the airflow switch.

IMPORTANT: Warranty is void unless tumble dryer is installed according to instructions in this manual. Installation should comply with minimum specifications and requirements detailed in this manual and applicable local gas fitting regulations, municipal building codes, water supply regulations, electrical wiring regulations, and any other relevant statutory regulations. Due to varied requirements, applicable local codes should be thoroughly understood and all pre-installation work arranged for accordingly.

Materials Required (Obtain Locally)	
All Models	Fused disconnect switch or circuit breaker on 1 Phase models. Circuit breaker on 3 Phase models.
Gas Models	One gas shut-off valve for gas service line to each tumble dryer.

Table continues...

Materials Required (Obtain Locally)	
Steam Models	One steam shut-off valve for steam service line to be connected upstream of solenoid steam valve. Two steam shut-off valves for each condensate return line. Flexible steam hoses with a 125 psig [pounds per square inch gauge] [862 kPa] working pressure for connecting steam coils. Refer to <i>Figure 24</i> for sizing and connection configurations. Two steam traps for steam coil outlets to condensate return line. Optional – Two vacuum breakers for condensate return lines.

IMPORTANT: 3 Phase Only – Each tumble dryer must be connected to its own individual branch circuit breaker, not fuses, to avoid the possibility of “single phasing” and causing premature failure of the motor(s).

Location Requirements

The tumble dryer must be installed on a level floor. Floor covering materials such as carpeting or tile should be removed.

To assure compliance, consult local building code requirements. The tumble dryer must not be installed or stored in area where it will be exposed to water and/or weather.

IMPORTANT: DO NOT block the airflow at the rear of the tumble dryer with laundry or other articles. Doing so would prevent adequate air supply to the combustion chamber of the tumble dryer.

A typical tumble dryer enclosure is shown in *Figure 2*.

IMPORTANT: Install tumble dryers with sufficient clearance for servicing and operation, refer to *Figure 2*.

IMPORTANT: The dryer must not be installed behind a lockable door, a sliding door or a door with a hinge on the opposite side to that of the tumble dryer, in such a way that a full opening of the tumble dryer door is restricted.



WARNING

To reduce the risk of severe injury, clearance of tumble dryer cabinet from combustible construction must conform to the minimum clearances, and/or local codes and ordinances.

W770R1

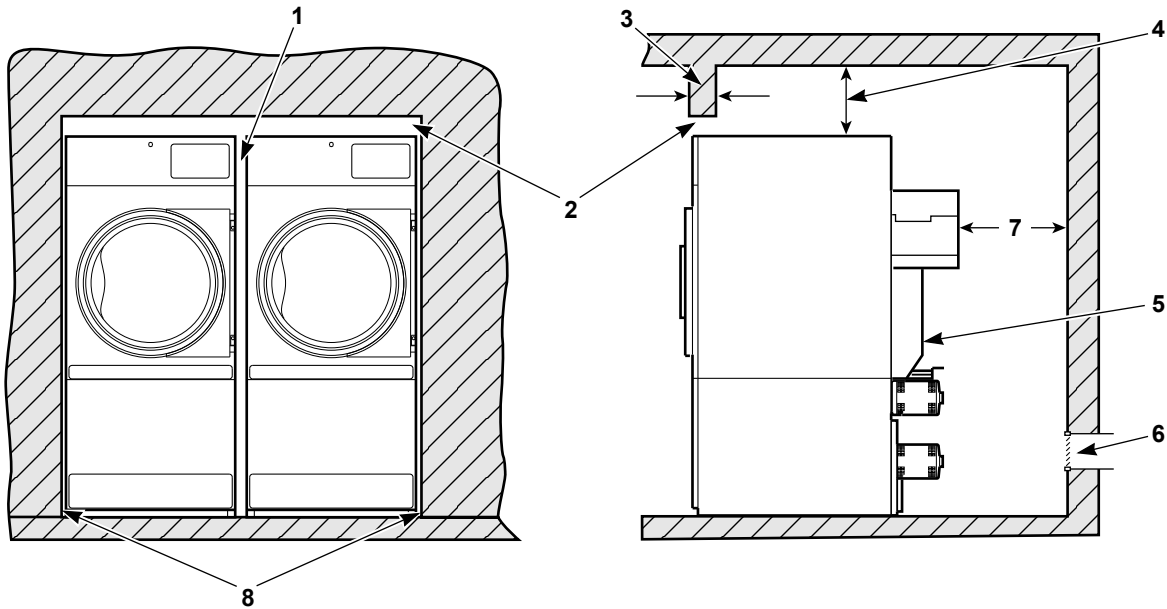

TMB2497N_SVG

NOTE: Shaded areas indicate adjacent structure.

1. 0.0 in. [0 mm] minimum, 0.5 in. [13 mm] recommended between machines for removal or installation
2. Allow 2-4 in. [51-100 mm] opening at top of machine to aid in removal or installation. A removable trim piece may be used to conceal the opening; zero clearance allowed for trim.
3. 4 in. [100 mm] maximum header thickness
4. Minimum clearance permitted for remainder: 12 in. [300 mm]
5. Guard
6. Provision for make-up air
7. 24 in. [610 mm] minimum, 36 in. [910 mm] recommended for maintenance purposes
8. 0.0 in. [0 mm] minimum, 0.25 in. [6 mm] recommended for removal or installation purposes

Figure 2

Position and Level the Tumble Dryer

1. Remove lint panel door, and unscrew the four shipping bolts (one at each corner).
2. Remove tumble dryer from pallet.
NOTE: DO NOT discard shipping bolts, they are used as machine leveling legs.
3. Remove four nuts from the literature package, and screw one fully on to each leveling leg.

4. Screw the four leveling legs (bolts) back into the level adjusting fittings from the bottom.
5. Slide tumble dryer to its permanent location. Adjust the leveling legs until the unit is level, or no more than 0.13 inch [3.3 mm] higher in the front. Refer to *Figure 3*. Tumble dryer must not rock. Lock leveling legs with nuts previously installed.

NOTE: The front of the tumble dryer should be slightly higher than the rear (approximately 0.13 inch [3.3 mm]). This will prevent the clothes, while tumbling, from wearing on the door glass gasket.

IMPORTANT: Keep tumble dryer as close to floor as possible. The unit must rest firmly on floor so weight of tumble dryer is evenly distributed.

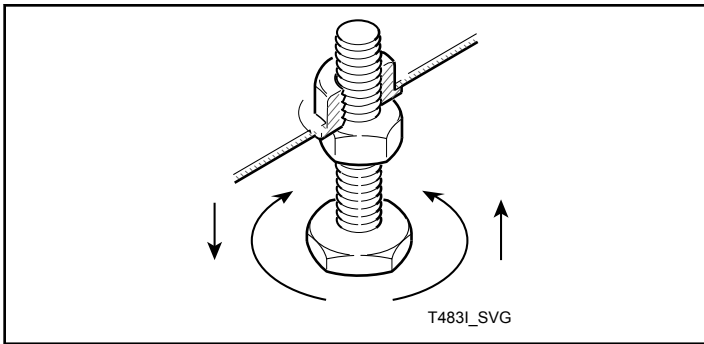

Figure 3

Fifth Leveling Leg

The stacked tumble dryer has a fifth leveling leg which is shipped in the up position. The fifth leveling leg **MUST BE** installed properly on the lower left side of the blower housing to stabilize the tumble dryer. Refer to *Figure 4*.

After leveling with the four cabinet leveling legs, lower the fifth leveling leg so it contacts the floor, and then secure the screws.

	CAUTION
<p>The stacked tumble dryer has a 5th leveling leg on the blower housing. It is very important to properly adjust this leg. Unit is back heavy and could rock or tip.</p>	
W250R1	

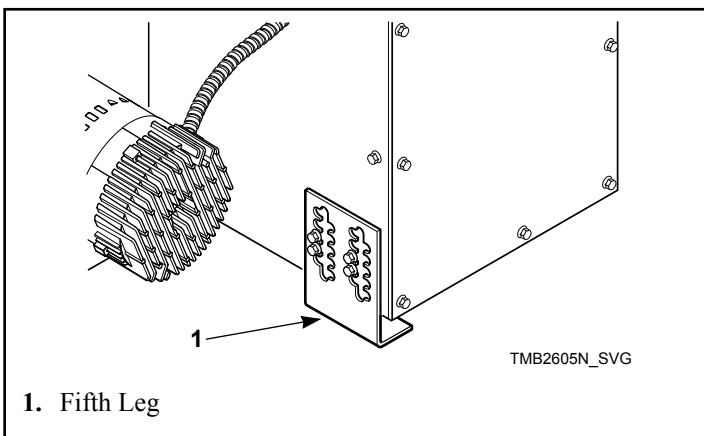

Figure 4

Fire Suppression System (Optional Equipment)

	WARNING
<p>ELECTRICAL SHOCK HAZARD. Electrical shock can result in death or serious injury. If the water dispensing system is activated, do not attempt to operate the tumble dryer. If the water dispensing system is activated, have the tumble dryer inspected by a qualified agency before operating the tumble dryer.</p>	
W879R1	

IMPORTANT: Main supplies of electricity and water to the tumble dryer should remain on at all times for the fire suppression system to work.

Check Local Codes and Permits

Call your local water company or the proper municipal authority for information regarding local codes.

IMPORTANT: It is your responsibility to have **ALL** plumbing connections made by a qualified professional to assure that the plumbing is adequate and conforms to local, state, and federal regulations or codes.

IMPORTANT: It is the installation or owner's responsibility to confirm that the necessary or required water, water pressure, pipe size, or connections are provided. Manufacturer assumes no responsibility if the fire suppression system is not connected, installed, or maintained properly.

Water Requirements

IMPORTANT: Water must be supplied to the fire suppression system, or the fire suppression system will not operate as intended.

To ensure the fire suppression system operates properly:

- Water supply requirements: 3/4 inch hose connections providing 15 gpm [57 lpm] minimum flow; Water pressure 20 psi [138 kPa] minimum, 120 psi [827 kPa] maximum; water temperature 40°F [4.5°C] minimum, 120°F [49°C] maximum must be maintained at all times.
- Electric power to the tumble dryer must be provided at all times.
- Perform preventative maintenance checks every month. Refer to Operation/Maintenance Manual.

NOTE: Water pressure under 20 psi [138 kPa] will cause low flow at water solenoid valve.

If the rear of the tumble dryer or the water supply is located in an area where it will be exposed to cold/freezing temperatures, provisions must be made to protect these water lines from freezing.

IMPORTANT: Temperature of the water supply must be kept between 40°F and 120°F [4.5°C and 49°C]. If water in the supply line or water solenoid valve freezes, the fire suppression system will not operate.

IMPORTANT: If temperature sensors inside the tumble dryer register a temperature below 40°F [4.5°C], the fire suppression system control will lock out. This feature protects against operation of the tumble dryer with a possible frozen water supply. Only when the temperature sensors register a temperature 40°F [4.5°C] or above will the machine reset for operation.

For installations where the tumble dryer must operate below 40°F [4.5°C], a cold weather fire suppression system relocation kit (part no. 44340301) is available. Refer to the instructions provided in the kit for proper installation.

IMPORTANT: Flexible supply line/coupling must be used. Solenoid valve failure due to hard plumbing connections will void the warranty. It is recommended that a filter or strainer be installed in the water supply line.

Water Connections

	<h2 style="margin: 0;">WARNING</h2>
<p>Electrical shock hazard. Can cause death or serious injury. If the water dispensing system is activated do not attempt to operate the dryer. If the water dispensing system is activated have the dryer inspected by a qualified agency before operating the dryer.</p> <ul style="list-style-type: none"> • CALL THE FIRE DEPARTMENT. • DO NOT disconnect electric power to the dryer. • DO NOT disconnect water to the dryer. • DO NOT touch the dryer. 	
<p style="font-size: small;">W932</p>	

Connect tumble dryer to a backflow preventer (vacuum breaker) before connecting to the public water main in all countries where local regulations require specific water approval certificates.

Two hoses and a Y-connector are provided with the tumble dryer to allow for connection of water supply to tumble dryer. DO NOT reuse old hose sets. The water connections are made to the water solenoid valve, located on the rear of the tumble dryer. The Y-connector provides a single female hose connection (Standard US 3/4-11 1/2 NH thread). Refer to *Figure 5* and *Figure 6*.

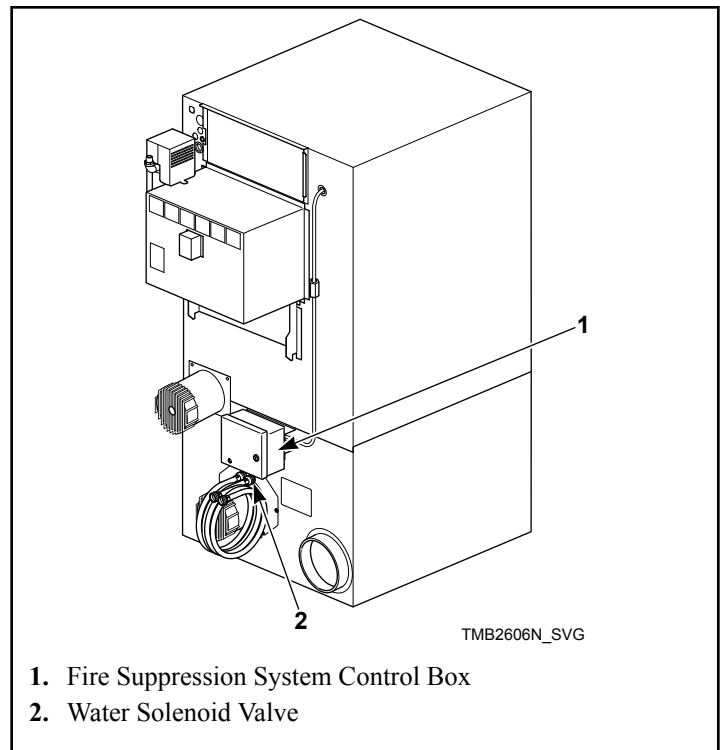

1. Fire Suppression System Control Box
2. Water Solenoid Valve

Figure 5

To connect the two hoses (supplied with tumble dryer), insert rubber washers (from literature pack) in water inlet hose couplings. Refer to *Figure 6*.

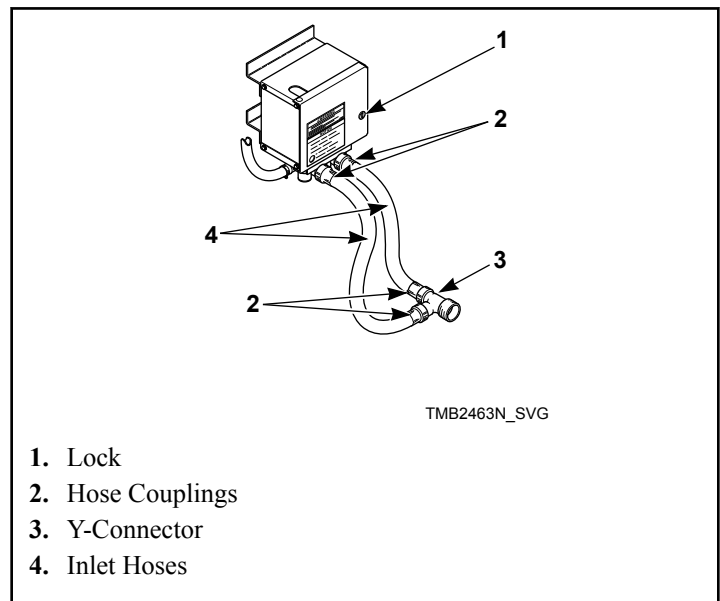

1. Lock
2. Hose Couplings
3. Y-Connector
4. Inlet Hoses

Figure 6

Connect inlet hoses to water supply. Flush the lines for approximately two minutes to remove any foreign materials that could clog the screens in the water mixing valve. This is especially important when installing a tumble dryer in a newly constructed or renovated building. Then connect the hoses to the Y-connector;

connect the Y-connector to the connections at the rear of the tumble dryer.

IMPORTANT: Thread hose couplings onto valve connections finger tight, then turn 1/4 turn with pliers. Do not cross thread or overtighten couplings.

IMPORTANT: Hoses and other natural rubber parts deteriorate after extended use. Hoses may develop cracks, blisters or material wear from the temperature and constant high pressure they are subjected to. All hoses should be checked on a yearly basis for any visible signs of deterioration. Any hose showing the signs of deterioration listed above should be replaced immediately. All hoses should be replaced every five years.

NOTE: Longer inlet hoses are available (as optional equipment at extra cost) if the hoses supplied with the tumble dryer are not long enough for installation. Order hoses as follows:

Part No. 20617 Inlet hose 8.0 feet [2.4 m]

Part No. 20618 Inlet hose 10 feet [3.0 m]

Electrical Requirements



WARNING

Electrical power must be provided to tumble dryer at all times. The fire suppression system will be inoperative if the main electrical power supply is disconnected.

W690R1

No independent external power source or supply connection is necessary. Power to operate the fire suppression system is from the tumble dryer main power supply.

Auxiliary Alarm

The fire suppression system provides an auxiliary output contact when the system is activated. During tumble dryer installation, you have the option to connect a separate alarm system to this auxiliary output. Potential uses of the auxiliary output include, but are not limited to: (1) sounds an alarm, (2) activates a building sprinkler system, (3) notifies a fire department, etc. Use of the auxiliary output is not required for the fire suppression system to operate, but may be used for additional protection.

The connection to the auxiliary output is made through the H-4 header connection inside the fire suppression control box. Refer to *Figure 7*. The relay is rated for 5 Amp, 250VAC max.

NOTE: The auxiliary output is activated during fire suppression system maintenance test sequence. Consider this fact prior to your system test every month. (Example: If the external system uses the auxiliary output to call the fire department, inform the fire department before and after the fire suppression system maintenance test. If the external system uses the auxiliary output to activate a building sprinkler, disconnect auxiliary output prior to test.)

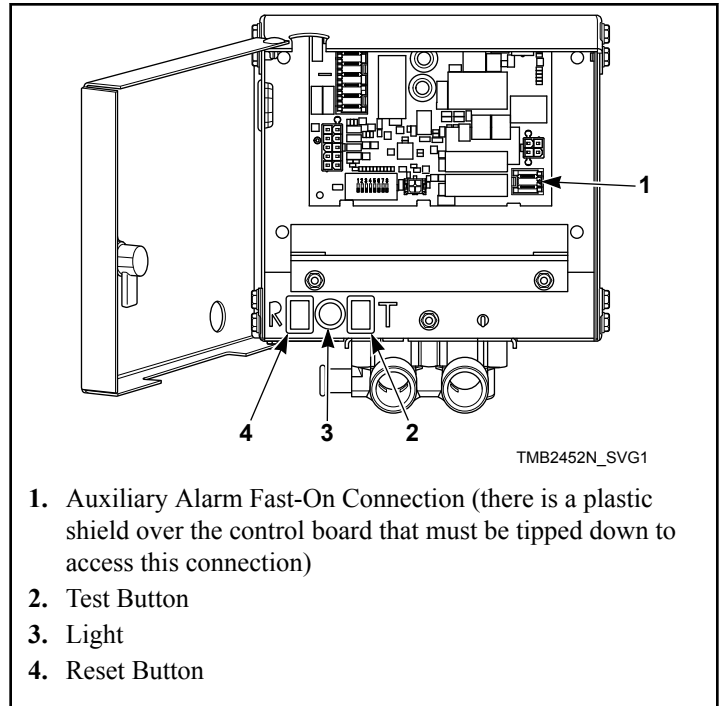

Figure 7

To Reverse the Loading Door (025, 030, 035 and 055 Series) (Design 3 Only)

The tumble dryer is delivered with a right hinged door, but the door can be changed to a left hinged position.

1. Disconnect power supply to tumble dryer.
2. Unlock and remove control panel. Remove two control assembly mounting screws from right side. Swing open control to access upper flange right guide lug assembly. Refer to *Figure 8*.
3. Remove lint panel.

IMPORTANT: Support door and hinge assembly securely to prevent it from dropping once side screws are removed from door hinge lug.

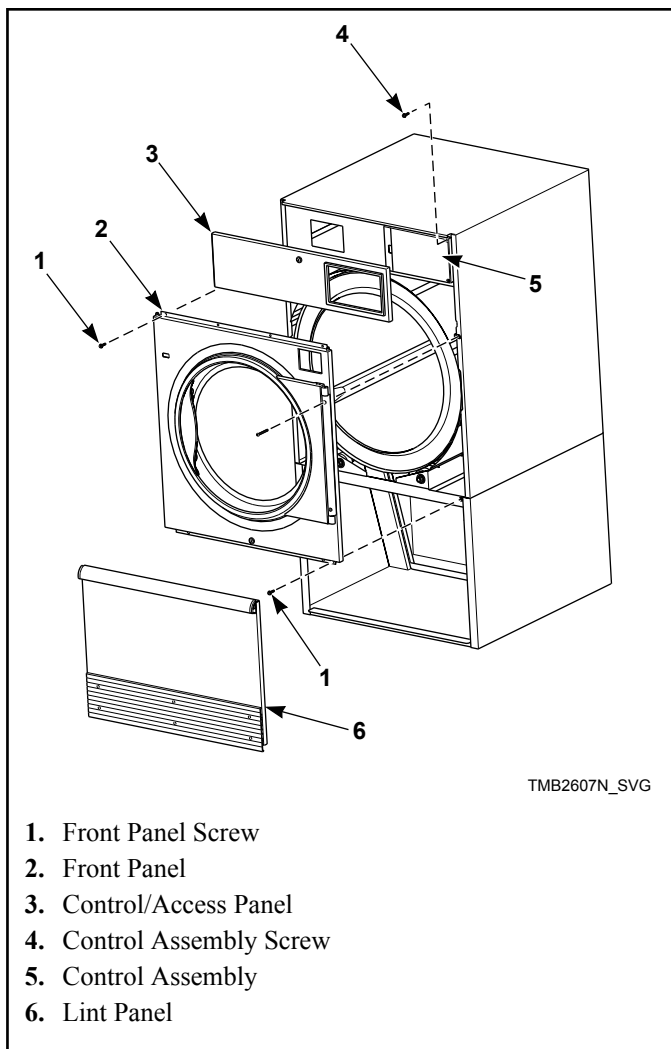

Figure 8

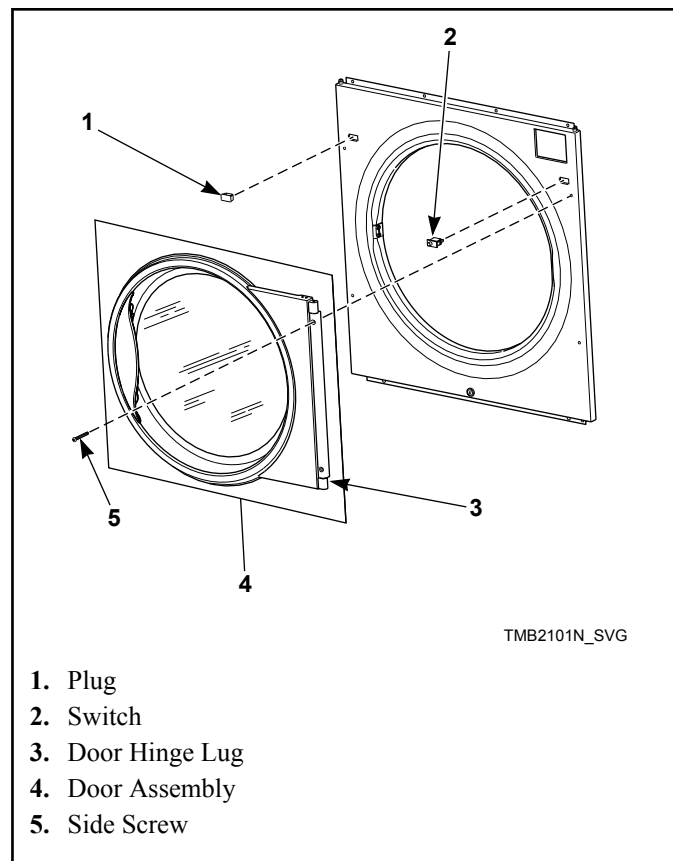
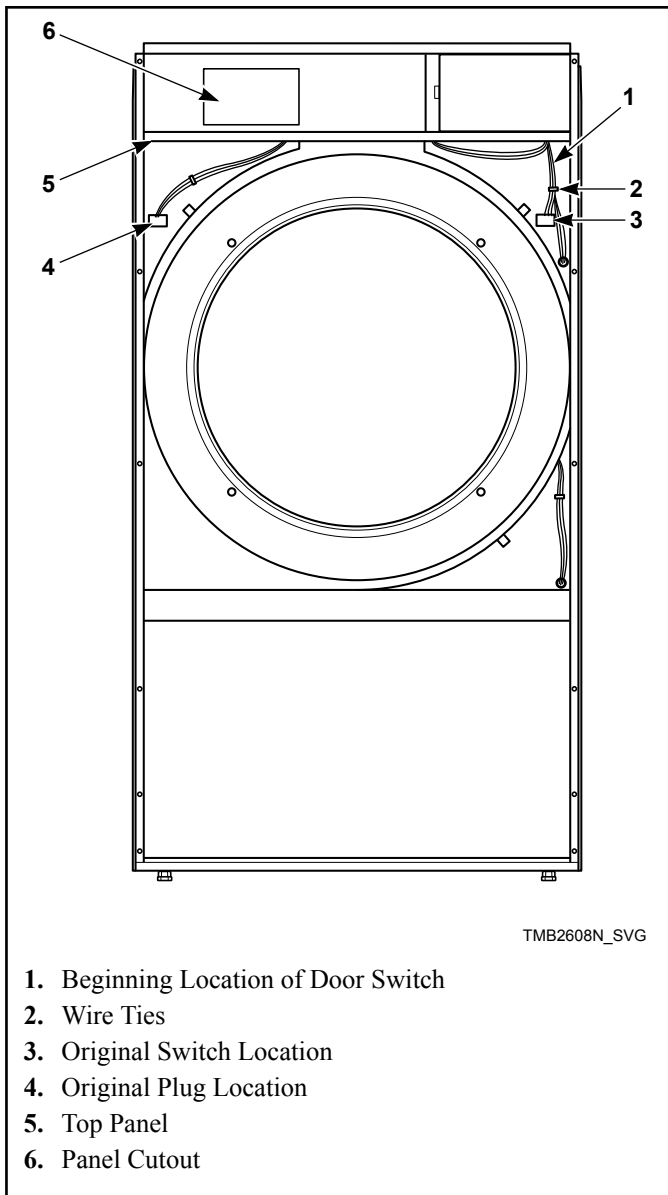

Figure 9

4. Remove four front panel screws. Refer to *Figure 8* . Keep door hinge cams in place on door hinge lug. Pull lug and door assembly off as one piece. Refer to *Figure 9* .
5. Remove remaining front panel screws. Refer to *Figure 8* . Disconnect door switch harness from switch. Take off front panel. Refer to *Figure 9* .
6. Exchange switch and plug locations. Depress tabs with an adjustable pliers to remove plug and switch from front panel. Reinstall switch, orienting button toward center of machine. Reinstall plug in switch's previous location. Refer to *Figure 9* .

IMPORTANT: Door switch must be oriented correctly in front panel receiving hole or tumble dryer will not operate.

7. Cut wire ties to remove door switch harness bundle. Be careful not to damage harness wires. Refer to *Figure 10* .
8. Reroute door switch harness up through the hole in the right side of the top panel. Use the panel cutout opening to then put harness down through the hole in the left side of the top panel and into the upper left corner of the cylinder enclosure.



1. Beginning Location of Door Switch
2. Wire Ties
3. Original Switch Location
4. Original Plug Location
5. Top Panel
6. Panel Cutout

Figure 10

IMPORTANT: Restore power to tumble dryer and test for proper operation of loading door switch. Refer to *Loading Door Switch* section for adjustment procedure. Tumble dryer should not start with door open; an operating tumble dryer should stop when door is opened.

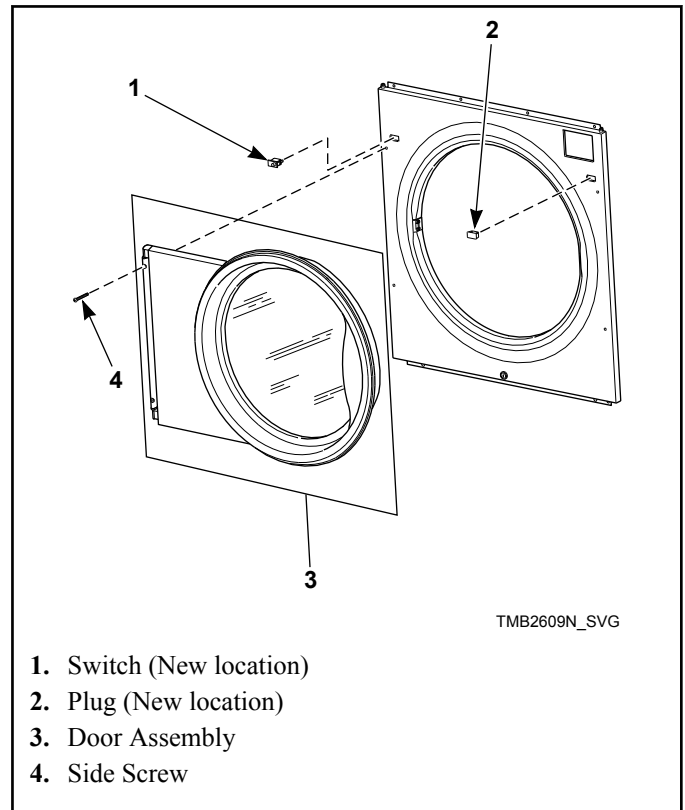

1. Switch (New location)
2. Plug (New location)
3. Door Assembly
4. Side Screw

Figure 11

NOTE: If machine is converted back to right hand hinge operation, the door switch harness must be rerouted. Harness must be rebundled with the lint panel switch harness. Wire ties must be used to secure harnesses. Wire ties (Part No. 55881) can be ordered from Genuine Parts.

Before Placing Tumble Dryer into Service

1. Ensure all panels and guards are in place.
2. Remove and discard wire tie from the airflow switch so it can swing freely. Refer to *Figure 12*.

9. Place front panel on machine, loosely attach four bottom screws. Connect door switch harness to switch in new location. Install door assembly and four front panel side screws loosely. Refer to *Figure 11*.
10. Check lint panel fit, adjusting front panel up or down as required. Tighten four front panel side screws to maintain position of front panel for proper lint panel clearance.
11. Remove lint panel. Fully tighten bottom screws on front panel.
12. Reinstall top screws and guide lugs.
13. Adjust door catch if necessary to allow 8 – 15 pounds [35.6N – 66.7N] pull at center of handle.
14. Reinstall control assembly using mounting screws.
15. Reinstall control panel and lint panel.

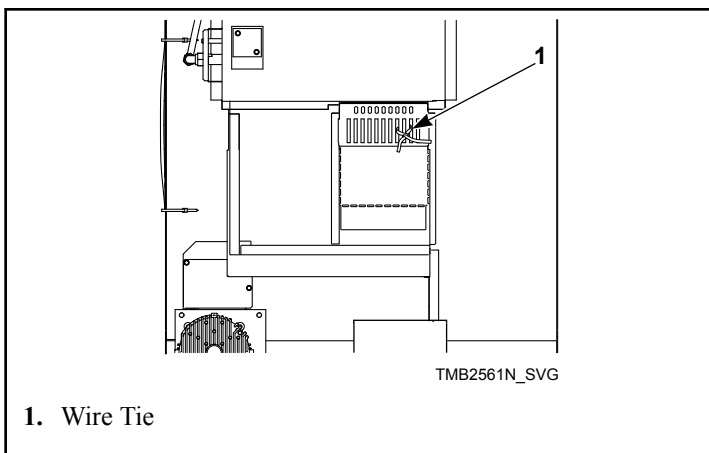

Figure 12

3. Pull out emergency stop button, if applicable.
4. Turn on electrical supply to tumble dryer.
5. Open the supply valve for gas or steam heated tumble dryers.
6. After performing the previous checks, start the tumble dryer by pressing START. (Refer to the Operating section for detailed instructions.) Release the start button and open the loading door. The cylinder should stop rotating within seven seconds after the door is opened a maximum of 0.79 inches [20 mm]. If it does not, adjust the loading door switch. Refer to Adjustments section.
7. **Gas Tumble Dryers:** Start the tumble dryer and check the burner flame. Adjust the air inlet shutter as required. Refer to Adjustments section.

IMPORTANT: The electronic ignition system will attempt to light the gas by sparking for the “trial for ignition” period. If gas does not ignite within this period, the ignition control will go into a safety lock-out and the valve will no longer open until the control is reset. On CSA models, the electronic ignition system is automatically reset. On AGA and IEC models the electronic ignition system must be manually reset. The control will pause the cycle and indicate that the ignition control needs to be reset. To reset the ignition control, press start key on the control while the access panel is open. The control will then prompt for the start key to be pressed again to restart the cycle. On all models, ignition lockout may occur due to air in the gas line or the gas shut-off valve being in the OFF position. If the air is bled out of the gas line, the gas shut-off valve is in the ON position, the gas service is properly connected and the tumble dryer continues to have heater errors and/or prompts for the ignition control to be reset, remove the tumble dryer from service.

8. Load the cylinder with a full load of clean rags and run to remove oil or dirt from cylinder.
9. Check the airflow switch operation by opening the lint panel; be sure to remove shipping wire tie from airflow switch prior to operation. Temporarily tape down the lint panel safety switch located behind the upper left corner of the lint panel. The heating systems should shut off when the lint panel is opened a maximum of 1.5 inches [38 mm] .

The airflow switch operation may be affected by shipping wire tie still in place, lack of make-up air, or an obstruction in the exhaust duct. These should be checked. If there is a problem, contact an authorized service person.

IMPORTANT: Remove tape from the lint panel safety switch before proceeding to the next step.

	WARNING
<p>Do not operate tumble dryer if airflow switch is faulty. An explosive gas mixture could collect in tumble dryer if airflow switch does not operate properly.</p>	
W407R1	

10. Clean cylinder by running a load of wet rags on one maximum heat cycle.

Models	Prepurge Time (seconds)	Interpurge Time (seconds)	Trial for Ignition (seconds)	Reset Lockout Condition By:
CSA	1	23	10 (attempts to ignite 3 times)	Automatically resets.
AGA and IEC	23	23	10	Press start key with access panel open.

If the tumble dryer does not meet ANY of the listed requirements, remove tumble dryer from use. Refer to *Removing Tumble Dryer from Service* section.

Required for IEC Models Only

Once machine is installed, please be sure to complete the following items:

- Review and verify machine operation with customer.
- Leave all literature and a signed Declaration of Conformity with customer.
- Review machine warranty information with customer.
- Apply cautionary stickers in language appropriate to country of sale. Market language label kits have been provided in the literature packet located in the cylinder. Position appropriate market language labels on the machine in the following regions prior to placing machine into service, if applicable:
 - On front panel at the periphery of cylinder access opening
 - On electrical box cover(s) (electric heat models and stack tumble dryers have two electrical box covers)
 - On rear panel (single dryers) or exhaust duct (stack dryers)
 - On front panel near emergency stop button (fire suppression system equipped models only)
 - On fire suppression control box (fire suppression system equipped models only)

Exhaust Requirements

Exhaust Requirements

	CAUTION
<p>Risk of fire. A clothes dryer produces combustible lint. Exhaust outdoors. Consult technical instructions for detailed exhaust specifications.</p>	
W933	

	WARNING
<p>To reduce the risk of fire, DO NOT use plastic or thin foil ducting to exhaust the tumble dryer.</p>	
W773R1	

	WARNING
<p>To reduce the risk of fire and accumulation of combustible gases, DO NOT exhaust tumble dryer air into a window well, gas vent, chimney or enclosed, unventilated area such as an attic wall, ceiling, crawl space under a building, or concealed space of a building.</p>	
W059R1	

Layout

Whenever possible, install tumble dryers along an outside wall where duct length can be kept to a minimum, and make-up air can be easily accessed. Construction must not block the airflow at the rear of the tumble dryer. Doing so would prevent adequate air supply to the tumble dryer combustion chamber.

Make-Up Air

A tumble dryer is forced air exhausted and requires provisions for make-up air to replace air exhausted by tumble dryer.

IMPORTANT: Do not obstruct flow of combustion and ventilation air.

Required Make-Up Air Opening (to the outside) for Each Tumble Dryer, in.² [cm²]	
Model	Opening
Standard 025/030 Series	110 [710]
Eco 025 Series	65 [420]
Standard 035/055 Series	144 [930]
Eco 035 Series	120 [775]
Standard T30 Series	220 [1,420]
Eco T30 Series	180 [1,160]
T45 Series	288 [1,860]

Make-up air openings with louvers will restrict airflow. The opening must be increased to compensate for area taken up and restrictions created by louvers. Contact the louver manufacturer for the exact specifications.

Make-up air openings in rooms containing tumble dryer(s) and/or gas fired hot water heater or other gravity vented appliances must be increased sufficiently to prevent downdrafts in any of the vents when all tumble dryers are in operation. Do not locate gravity vented appliances between tumble dryer(s) and make-up air openings. If it is necessary to duct make-up air to tumble dryer(s), increase area of duct work by 25% to compensate for restrictions in air movement.

Venting

	WARNING
<p>To reduce the risk of fire due to increased static pressure, we do not recommend installation of in-line secondary lint filters or lint collectors. If secondary systems are mandated, frequently clean the system to assure safe operation.</p>	
W749	

IMPORTANT: Installing in-line filters or lint collectors will cause increased static pressure. Failure to maintain the secondary lint system will decrease tumble dryer efficiency and may void machine warranty.

For maximum efficiency and minimum lint accumulation, tumble dryer air must be exhausted to the outdoors by the shortest possible route.

Proper sized exhaust ducts are essential for proper operation. All elbows should be sweep type. Exhaust ducts must be assembled so the interior surfaces are smooth, so the joints do not permit the accumulation of lint. **DO NOT** use plastic, thin foil or Type B flexible ducts - rigid metal ducts are recommended. Use exhaust ducts made of sheet metal or other noncombustible material. **DO NOT** use sheet metal screws or fasteners on exhaust pipe joints which extend into the duct and catch lint. Use of duct tape or pop-rivets on all seams and joints is recommended, if allowed by local codes.

Verify that old ducts are thoroughly cleaned out before installing new tumble dryer(s).

	WARNING
<p>Improperly sized or assembled ductwork causes excess back pressure which results in slow drying, lint collecting in the duct, lint blowing back into the room, and increased fire hazard.</p>	
W355	

NOTE: Exhaust ducts must be constructed of sheet metal or other noncombustible material. Such ducts must be equivalent in strength and corrosion resistance to ducts made of galvanized sheet steel not less than 0.02 inches [0.50 mm] thick.

Where the exhaust duct pierces a combustible wall or ceiling, the opening must be sized per local codes. The space around the duct may be sealed with noncombustible material. Refer to *Figure 14*.

IMPORTANT: For best performance provide an individual exhaust duct for each tumble dryer. Do not install a gas water heater in a room containing tumble dryers. It is better to have the water heater in a separate room with a separate air inlet.

NOTE: Proper venting will ensure that any condensate is subsequently re-evaporated and discharged.

NOTE: On IEC approved tumble dryers where it may be required, an exhaust adapter is available to convert to female outlet. Contact local distributor or manufacturer.

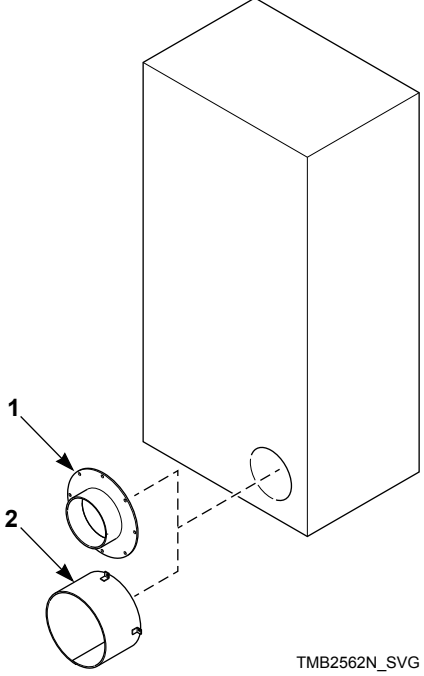

TMB2562N_SVG

1. 25, 30, 35, 55 Models
2. Not Applicable

Figure 13

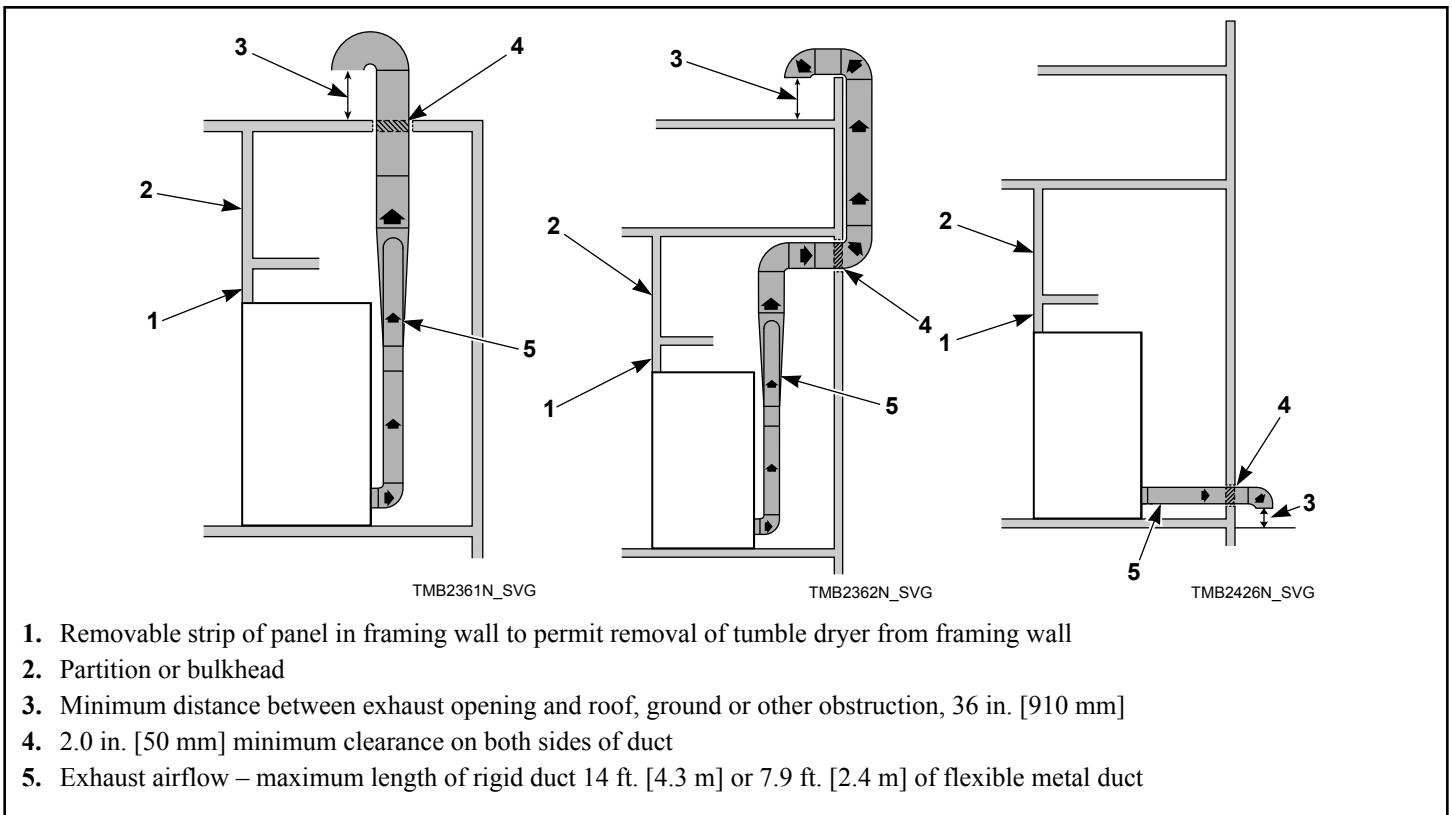

Figure 14

NOTE: Do not install wire mesh or screen in exhaust duct opening to avoid lint build-up or impacting proper discharge of air from tumble dryers.

NOTE: Where exhaust duct pierces a combustible wall or ceiling, the opening must be sized per local codes.

NOTE: Inside of duct must be smooth. Do not use sheet metal screws to join sections.

NOTE: Locate exhaust far enough away from make-up air location to prevent re-introduction.

Consult your local building code for regulations which may also apply.

Individual Venting

For maximum efficiency and performance, it is preferred to exhaust tumble dryer(s) individually to the outdoors.

IMPORTANT: At no point may the cross sectional area of installed venting be less than the cross sectional area of the exhaust outlet of the tumble dryer.

The exhaust duct must be designed so the static back pressure measured 12 inches [305 mm] from the exhaust outlet does not exceed the maximum allowable pressure specified in the Specifications and Dimensions Table or on the installation sticker on the rear of the tumble dryer.

NOTE: Static back pressure must be measured with the tumble dryer running.

The maximum allowable length venting is 14 feet [4.3 m] and two 90° elbows or equivalent. If the equivalent length of a duct required for an installation exceeds the maximum allowable equivalent length, the diameter of a round duct must be increased by 10% for each additional 20 feet [6.1 m]. Cross section area of a rectangular duct must be increased by 20% for each additional 20 feet [6.1 m]. Refer to *Table 13* to determine equivalent venting.

Duct Diameter	Equivalent Length of Rigid Straight Duct
8 in. [203 mm]	One 90° elbow = 9.3 ft. [2.8 m]
10 in. [254 mm]	One 90° elbow = 11.6 ft. [3.5 m]
12 in. [305 mm]	One 90° elbow = 14 ft. [4.3 m]
14 in. [356 mm]	One 90° elbow = 16 ft. [4.9 m]

Table 13 continues...

Duct Diameter	Equivalent Length of Rigid Straight Duct
16 in. [406 mm]	One 90° elbow = 18.7 ft. [5.7 m]
18 in. [457 mm]	One 90° elbow = 21 ft. [6.4 m]
Equivalent Length (meter) = 1.17 x Duct Diameter (mm)	

Table 13

Example: A 12 inch [305 mm] diameter duct’s equivalent length of 14 feet [4.3 m] of duct and two 90° elbows is:

Equivalent Length

= 14 ft. [4.3 m] + (2) 90° elbows

= 14 ft. [4.3 m] + 14 ft. [4.3 m] + 14 ft. [4.3 m]

= 42 ft. [12.8 m]

With the tumble dryer in operation, airflow at any point in the duct should be at least 1200 feet/min. [366 m/min.] to ensure that lint remains airborne. If 1200 feet/min. [366 m/min.] cannot be maintained, schedule monthly inspections and cleaning of the ductwork.

NOTE: The maximum length of a flexible metal duct must not exceed 7.9 ft. [2.4 m] as required to meet UL2158, clause 7.3.2A.

Manifold Venting

IMPORTANT: Do not exhaust tumble dryers into a flue used by other appliances.

While it is preferable to exhaust tumble dryers individually to the outdoors, a main collector duct may be used if it is sized according to *Figure 16* and *Figure 17*. This illustration indicates mini-

imum diameters, and should be increased if the collector length exceeds 14 feet [4.3 m] and two 90° elbows. The diameter of a round duct must be increased by 10% for each additional 20 feet [6.1 m]. Cross sectional area of a rectangular or square duct must be increased 20% for each additional 20 feet [6.1 m]. Refer to *Table 14* to determine equivalent ducting sizing. The collector duct may be rectangular or square in cross section, as long as the area is not reduced. Provisions **MUST** be made for lint removal and cleaning of the collector duct.

The vent collector system must be designed so the static back pressure measured 12 inches [305 mm] from the exhaust outlet does not exceed the maximum allowable pressure specified in the Specifications and Dimensions Table or on the installation sticker on the rear of tumble dryer. Static back pressure must be measured with all tumble dryers vented into the collector operating.

NOTE: Never connect a tumble dryer duct at a 90° angle to the collector duct. Refer to *Figure 15*. Doing so will cause excessive back pressure, resulting in poor performance. Never connect two tumble dryer exhaust ducts directly across from each other at the point of entry to the collector duct.

With the tumble dryer in operation, airflow at any point in the duct should be at least 1200 feet/min. [366 m/min.] to ensure that lint remains airborne. If 1200 feet/min. [366 m/min.] cannot be maintained, schedule monthly inspections and cleaning of the ductwork.

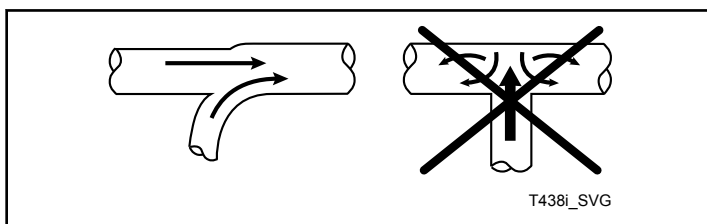

Figure 15

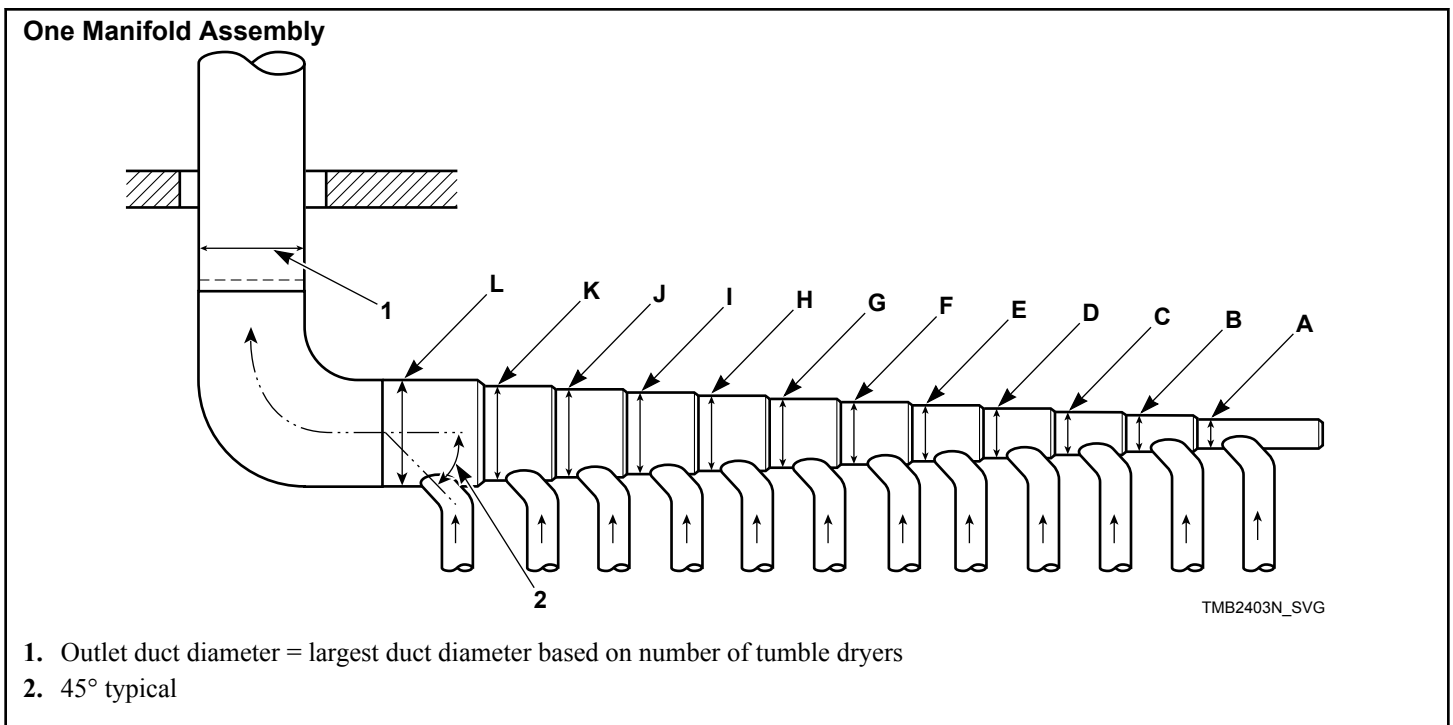

Figure 16

Duct Station	Eco Line 025	Standard Line 025, Eco T30 and all 030 Series	035, 055 and Standard T30 Series	T45 Series
A	4 in. [102 mm]	6 in. [152 mm]	8 in. [203 mm]	10 in. [254 mm]
B	6 in. [152 mm]	10 in. [254 mm]	12 in. [305 mm]	15 in. [381 mm]
C	8 in. [203 mm]	12 in. [305 mm]	15 in. [381 mm]	18 in. [457 mm]
D	10 in. [254 mm]	14 in. [356 mm]	17 in. [432 mm]	21 in. [533 mm]
E	12 in. [305 mm]	16 in. [406 mm]	19 in. [483 mm]	24 in. [610 mm]
F	12 in. [305 mm]	18 in. [457 mm]	21 in. [533 mm]	26 in. [660 mm]
G	14 in. [356 mm]	19 in. [483 mm]	23 in. [584 mm]	28 in. [711 mm]
H	14 in. [356 mm]	20 in. [508 mm]	24 in. [610 mm]	30 in. [762 mm]
I	15 in. [381 mm]	22 in. [559 mm]	26 in. [660 mm]	32 in. [813 mm]
J	16 in. [406 mm]	23 in. [584 mm]	27 in. [686 mm]	33 in. [838 mm]
K	17 in. [432 mm]	24 in. [610 mm]	28 in. [711 mm]	35 in. [889 mm]
L	18 in. [457 mm]	25 in. [635 mm]	30 in. [762 mm]	36 in. [914 mm]

Table 14

NOTE: *Table 14* represents tumble dryers with the same vent size. If multiple vent sizes are used, consult a local HVAC specialist.

NOTE: Duct clean-out recommended every 6 feet [0.18 m].

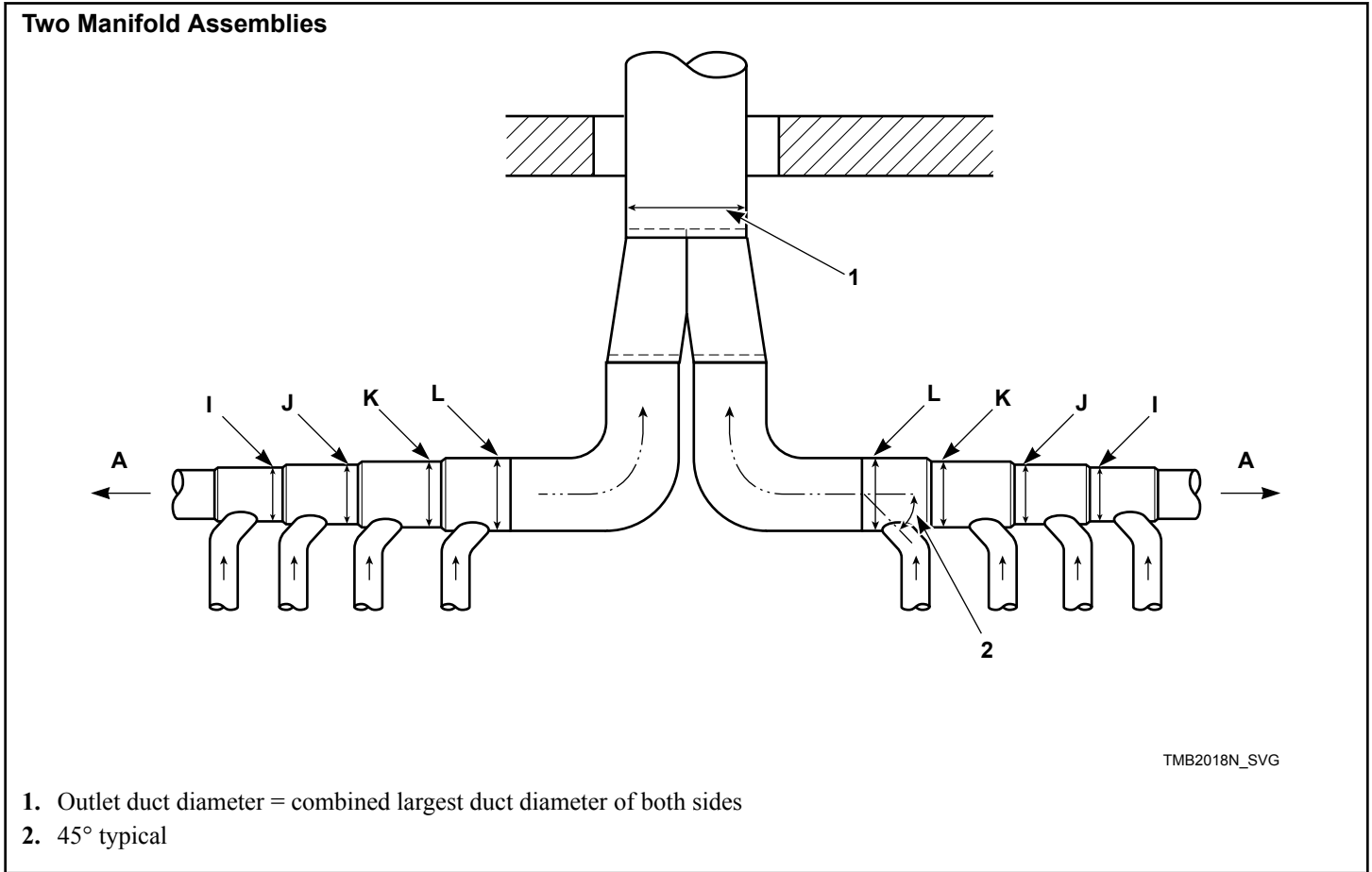



Figure 17

Refer to *Table 14* for measurements for each manifold.

Gas Requirements

Gas Requirements

	CAUTION
<ul style="list-style-type: none"> • Thoroughly test all piping for leaks before operating. All fittings and piping must be tight and supported against breakage and vibration. • Turn off primary gas line shut off cock when not in use (overnight, weekends, holidays, etc.). 	
W934	

	WARNING
<p>To reduce the risk of fire or explosion, DO NOT CONNECT THE GAS LINE TO THE TUMBLE DRYER IF THE GAS SERVICE IS NOT THE SAME AS THAT SPECIFIED ON THE TUMBLE DRYER SERIAL PLATE! It will first be necessary to convert the gas burner orifice and gas valve. Appropriate conversion kits are available.</p>	
W060R1	

	WARNING
<p>To reduce the risk of gas leaks, fire or explosion, use a new flexible stainless steel connector.</p>	
W774	

IMPORTANT: Any product revisions or conversions must be made by the Manufacturer's Authorized Dealers, Distributors or local service personnel.

IMPORTANT: The tumble dryer must be isolated from the gas supply piping system by closing its individual manual shut-off valve during any pressure testing of the gas supply piping system. Gas supply pressure must never exceed 1/2 PSI [3.45 kPa, 34.5 mbar] during leak testing. Gas supply must provide 6.5+/-1.5 inches [1.62+/-0.37 kPa, 16.17+/-3.73 mbar] with all gas appliances firing.

NOTE: For gas valves with a manual shut-off switch on the gas valve, the shut-off switch does not protect the valve from this pressure test. Use the individual manual shut-off valve from the gas supply piping system to protect the gas valve.

IMPORTANT: The installation must comply with local codes or, in the absence of local codes:

- with the latest edition of the "National Fuel Gas Code," ANSI Z223.1/NFPA 54 in the U.S.A.
- with CAN/CSA-B149.1 Natural Gas and Propane Installation Code in Canada
- In Australia and New Zealand, installation must comply with the Gas Installations Standard AS/NZS 5601 Part 1: General Installations.
- In the EU, installation must comply with the installation regulations of the country of destination.

IMPORTANT: For Australian models, do not remove the gas type label on the rear of the unit.

Obtain specific gas service pipe size from the gas supplier. Refer to *Table 16* and *Table 17* for general pipe size.

The following must be furnished and installed by the customer for the gas service line to each tumble dryer. Refer to *Figure 18*.

- Sediment traps
- Shut-off valves
- Supply pressure taps (1/8 NPT minimum) (refer to *Figure 18*)
- Union at gas supply connection (listed to ANSI Z21.24 and CSA 6.10)

It is important that equal pressure be maintained at all tumble dryer gas connections. This can be done by installing a 1 inch pipe gas loop to maintain equal pressure at all gas connections. Refer to *Figure 22*.

	WARNING
<p>To reduce the risk of fire or explosion, if the tumble dryer is to be connected to Liquefied Petroleum (L.P.) gas, a vent to the outdoors must be provided in the room where the tumble dryer is installed.</p>	
W062R1	

Before installation, check that the local distribution conditions, nature of gas and pressure, and the adjustment of the appliance are compatible.

NATURAL GAS supply pressures with all gas appliances running (tumble dryers, water heaters, space heaters, furnace, etc.):

	North America Models	Australia Models	CE Models
Maximum	10.5 in. w.c.	2.61 kPa	Refer to <i>Table 15</i>
Recommended	6.5 in. w.c.	1.62 kPa	
Minimum	5 in. w.c.	1.13 kPa	

An in-line pressure regulator may be required if the line pressure exceeds 10.5 water column inches [26.1 mbar, 2.61 kPa] with all gas appliances running.

PROPANE/LIQUID PETROLEUM GAS (L.P.G.) supply pressures with all gas appliances running (tumble dryers, water heaters, space heaters, furnace, etc.):

	North America Models	Australia Models	CE Models
Maximum	13 in. w.c.	3.23 kPa	Refer to <i>Table 15</i>
Recommended	11 in. w.c.	2.74 kPa	
Minimum	10 in. w.c.	2.49 kPa	

Gas Category	Country	Gas	Category	Supply Pressure (mbar)			Manifold Pressure (mbar)
				nominal	minimum	maximum	
II _{2H3B/P}	BG, CY, CZ, DK, EE, FI, HR, LT, NO, SE, SI SK	G20	2H	20	17	25	8.0
		G30/31	3B/P (30)	30 (28-30)	25	35	*
II _{2H3B/P}	HU	G20	2H	25	18	33	8.0
		G30/31	3B/P	50	42.5	57.5	27.5
II _{2H3B/P}	AT, CH	G20	2H	20	17	25	8.0
		G30/31	3B/P	50	42.5	57.5	27.5
II _{2H3+}	CH, ES, GB, GR, IE, IT, TR	G20	2H	20	17	25	8.0
		G30	3+ (28-30/37) Butane	30 (28-30)	25	35	*
		G31	3+ (28-30/37) Propane	37	25	45	*
II _{2E3B/P}	PL	G20	2E	20	17	25	8.0
		G30	3B/P	30 (28-30)	25	35	*
II _{2E3B/P}	LU	G20	2E	20	17	25	8.0
		G30/31	3B/P	50	42.5	57.5	27.5
II _{2E3B/P} II _{2E(LL)3B/P}	DE	G20	2E(LL)/2E	20	17	25	8.0
		G25	2E(LL)	20	17	25	12.0
		G30/31	3B/P	50	42.5	57.5	27.5
II _{2E(r)3+}	FR	G20	2E(r)	20	17	25	8.0
		G25	2E(r)	20	17	25	12.0
		G30	3+ (30/37) Butane	30 (28-30)	25	35	*
		G31	3+ (30/37) Propane	37	25	45	*
II _{2L3B/P}	NL	G25	2L	25	20	30	12.0
		G30	3B/P	30 (28-30)	25	35	*

Table 15 continues...

Gas Category	Country	Gas	Category	Supply Pressure (mbar)			Manifold Pressure (mbar)
				nominal	minimum	maximum	
II _{2L3B/P}	RO	G25	2L	20	17	25	12.0
		G30	3B/P	30 (28-30)	25	35	*
I _{3B/P}	IS, MT	G30	3B/P	30 (28-30)	25	35	*
I _{2E(R)}	BE	G20	2E(R) 20/25	20	17	25	8.0
		G25	2E(R) 20/25	20	17	25	12.0
I ₃₊	BE	G30	3+ (28-30/37) Butane	30 (28-30)	25	35	*
		G31	3+ (28-30/37) Propane	37	25	45	*
* Appliance regulator out of action							

Table 15

Check manifold pressure. It is important that gas be supplied to the tumble dryer in accordance with the requirements on the serial plate. Refer to table below and *Figure 1*. If the manifold pressure required adjustment, refer to *How to Adjust Gas Valve Governor/Regulator*.

	North America Models	Australia Models	CE Models
Natural Gas	3.5 in. w.c.	0.87 kPa	Refer to <i>Table 15</i>
Propane/ L.P.G.	10.5 in. w.c.	2.61 kPa	

The connection of gas supply to the appliance shall be made with a flexible hose suitable for the appliance category in accordance with national installation regulations of the country of destination. If in doubt, the installer shall contact the supplier.

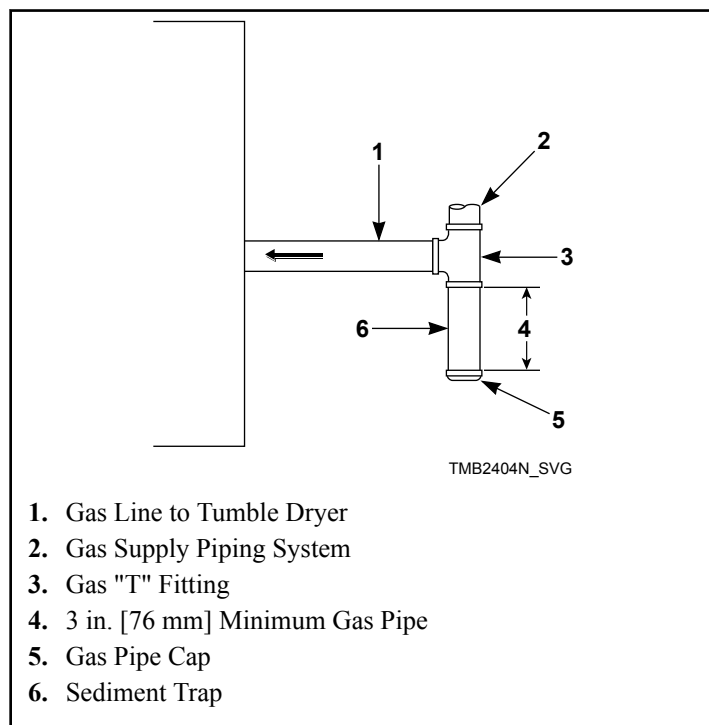

1. Gas Line to Tumble Dryer
2. Gas Supply Piping System
3. Gas "T" Fitting
4. 3 in. [76 mm] Minimum Gas Pipe
5. Gas Pipe Cap
6. Sediment Trap

Figure 18

How to Change Burner Orifice Size

1. Disconnect electrical power from tumble dryer. Close gas shut-off valve to tumble dryer. Refer to *Figure 19* .

	WARNING
When converting the tumble dryer to a different gas or pressure, first verify that the supply inlet pressure is equipped with a pressure regulator (located ahead of the tumble dryer) that will maintain the gas supply at the inlet pressure specified.	
W430R1	

2. Remove orifice holder. Unscrew orifice holder nut near gas valve. Remove the burner orifice(s) from orifice holder. Refer to *Figure 20* .
3. Install the new, correct burner orifice(s). Refer to *Figure 21* and *Table 15* . Torque each to 9 – 10 Nm.
4. Reinstall orifice holder assembly to gas valve, making certain burner orifice(s) are in line with burner tube opening. Refer to *Figure 21* .
5. Commission tumble dryer for use.

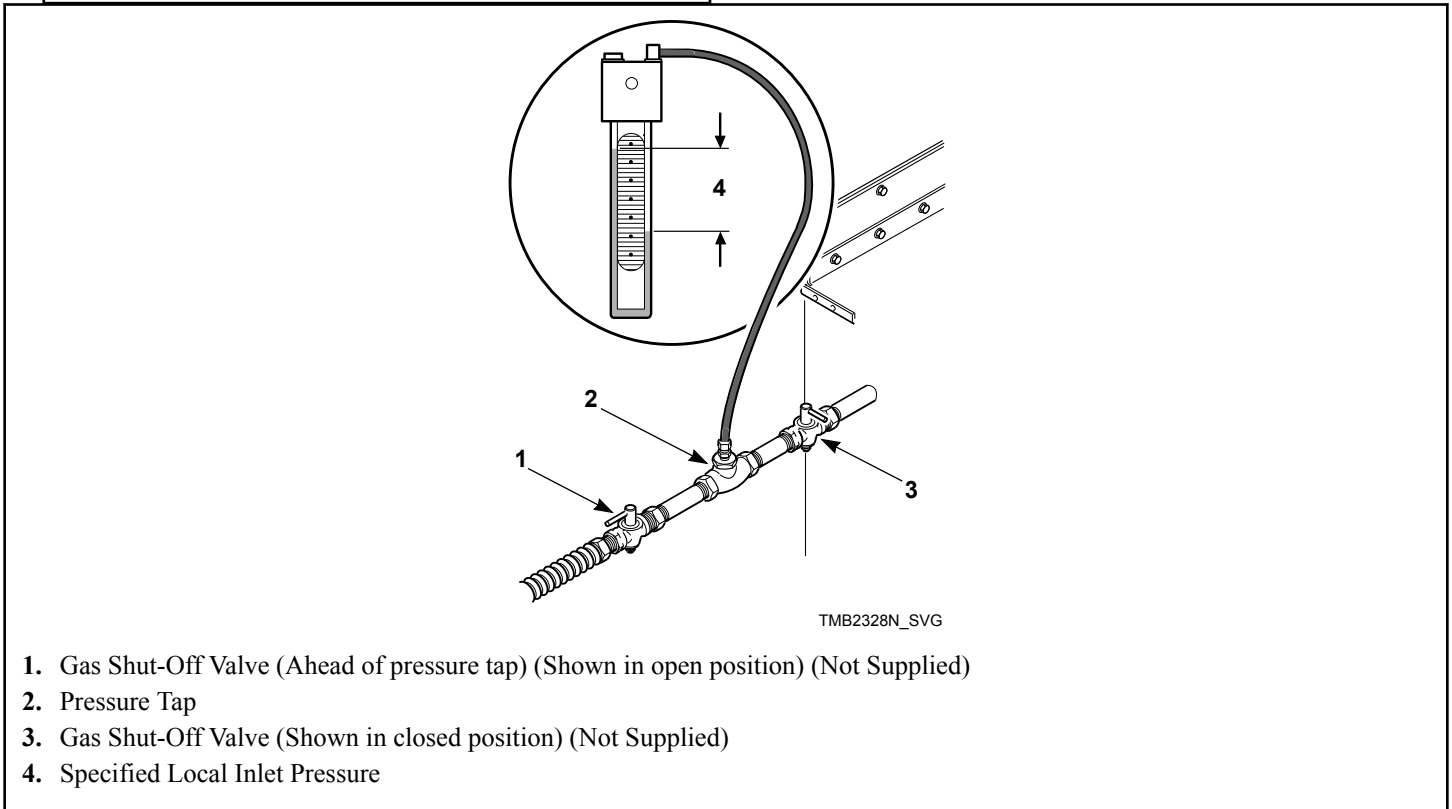

Figure 19

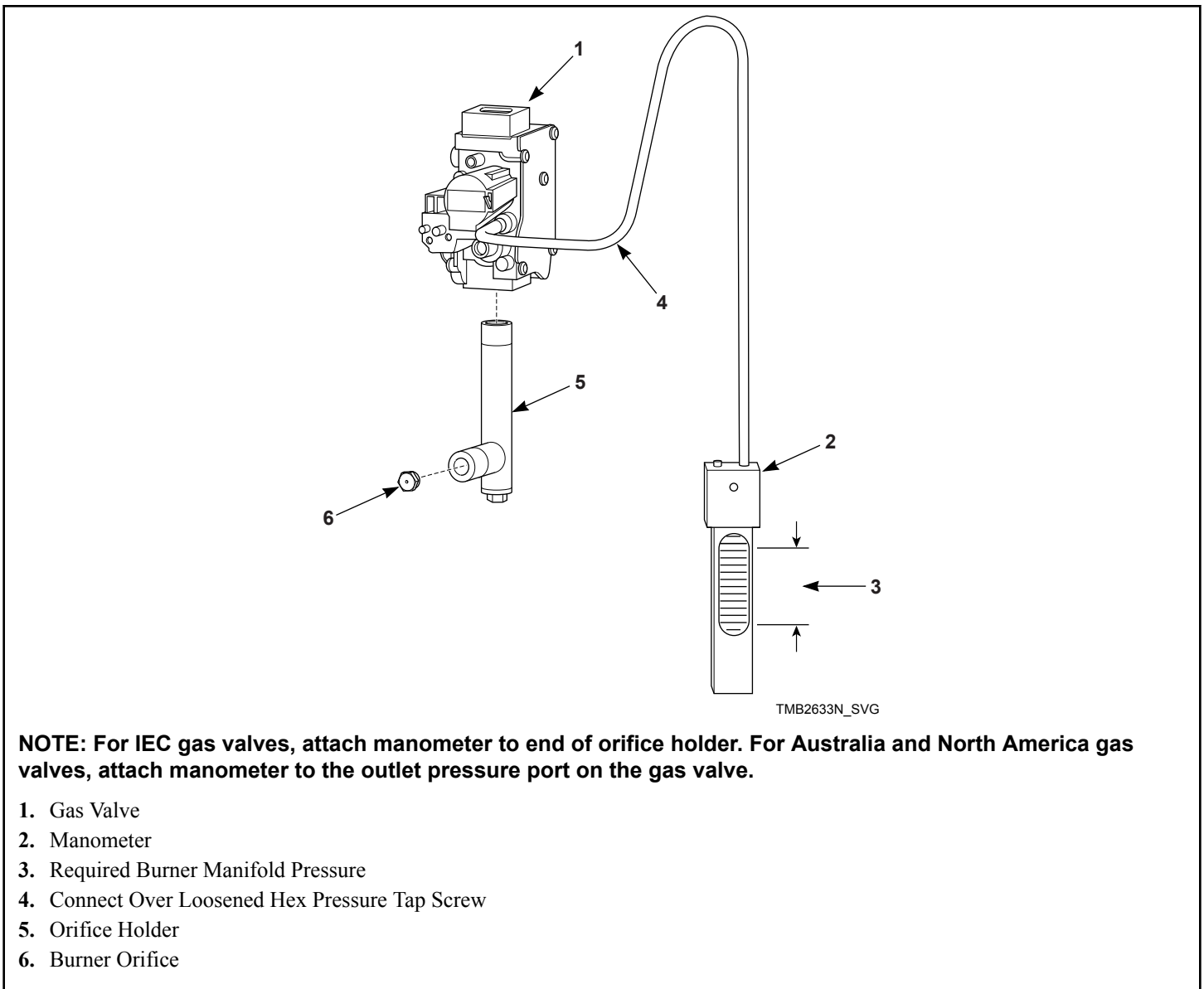

Figure 20

How to Adjust Gas Valve Governor/Regulator

1. Check gas burner orifice (manifold) pressure as follows. Refer to *Figure 20*.
2. Remove screw plug from pressure tap.
3. Connect a “U”-tube manometer (or similar pressure gauge) to the burner orifice (manifold) pressure tap.
4. Start tumble dryer and note pressure once flame is burning. Remove regulator cap and adjust regulator screw until the burner orifice pressure per applicable table is achieved. Replace regulator cap. Refer to *Figure 20*.
5. Commission tumble dryer for use.

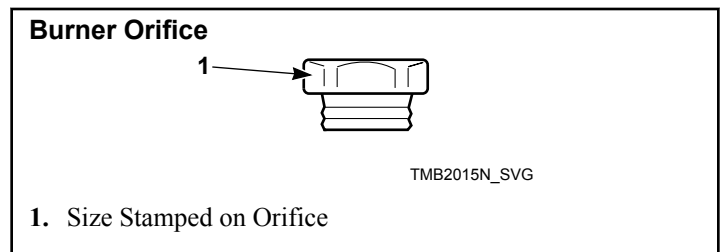

Figure 21

Installing CE Gas Tumble Dryer

This information is to be used when installing gas tumble dryers in countries and/or on gases different than the machine's factory configuration. Tumble Dryers are supplied from the factory for operation with natural gas categories 2H, 2E, 2L, 2E(LL), 2E(r), 2E(R) or unregulated L.P.G. categories 3 B/P, 3+. To install tumble dryers for regulated LPG category 3B/P requires a conversion kit.

Tumble dryers are built in two different configurations:

- Natural Gas – regulated/governor
- Liquefied Petroleum Gas (L.P.G.) – not regulated/no governor

For converting models from Natural Gas to L.P.G., order the appropriate kit listed in *Gas Requirements* section.

Serial plates supplied from the factory are configured for:

- Natural Gas, standard rate
 - AT/BG/CH/CY/CZ/DK/EE/FI/HR/LT/NO/SE/SI/SK: II_{2H3B/P}
 - CH/ES/GB/GR/IE/IT/TR: II_{2H3+}
 - DE/LU/PL: II_{2E3B/P}
- Natural Gas, Eco rate
 - AT/BG/CH/CY/CZ/DK/EE/ES/FI/GB/GR/HR/IE/IT/LT/NO/SE/SI/SK/TR: I_{2H}
 - DE/LU/PL: I_{2E}
- L.P.G.
 - BE/CH/ES/FR/GB/GR/IE/IT/TR: I₃₊

These instructions pertain to the situations when the country of use or gas supply is different than that on the serial plate. When installing in a different country, peel off the appropriate country sticker (included in literature packet with tumble dryer) and apply it to the serial plate over the existing country information. Adjust manifold pressure as applicable, per *Table 15*.

Units installed in France (FR) require a gas connection adapter having ISO228 (BSPP, G) parallel threads and a sealing washer. The adapter must have a sufficient flat area to seat the sealing washer.

Adjusting Manifold Pressure for Natural Gas G20 or G25

1. If country/gas category designation required is not listed on the serial plate, affix the appropriate country/gas category label supplied over the main serial plate designations.
2. Verify gas supply pressure and adjust as necessary. Refer to *Figure 1*.
3. Verify manifold pressure. Refer to *How to Adjust Gas Valve Governor/Regulator* and adjust as necessary.

Adjusting Supply Pressure for L.P.G. G30 or G31

1. If country/gas category designation required is not listed on the serial plate, affix the appropriate country/gas category label over the main serial plate designations.
2. Verify gas supply pressure and adjust as necessary. Refer to *Figure 1*.

Converting From Natural Gas to L.P.G. or From Unregulated L.P.G. to Regulated L.P.G.

1. Refer to table below to determine conversion kit part number required.
2. Follow instructions supplied in conversion kit.

	CSA and AGA Models	CE Models
025 Series	70550201	70551901
030 Series	70550202	70551902
T30 Series	70550205	70551905
035 Series	70550203	70551903
T45 Series	CSA - 70550206 AGA - 70550207	70551906
055 Series	70550204	70551904

CE GASES refer to *Installing CE Gas Tumble Dryer* section.

Start-Up Procedure

Turn on gas and check all pipe connections (internal and external) for gas leaks with a non-corrosive leak detection fluid. Purge air in gas service line by operating the tumble dryers in the drying mode. If burner does not light and unit goes into lockout, press start key on the control while the access panel is open. The control will then prompt for the start key to be pressed again to restart the cycle. Repeat these steps until burner ignites. Use pipe compound, resistant to actions of L.P. gas, on all pipe threads.

	WARNING
<p>Check all pipe connections, internal and external, for gas leaks using a non-corrosive leak detection fluid. To reduce the risk of explosion or fire, DO NOT USE AN OPEN FLAME TO CHECK FOR GAS LEAKS! Gas connections should be checked daily for leakage.</p>	
W924	

Gas Supply Pipe Sizing and Looping

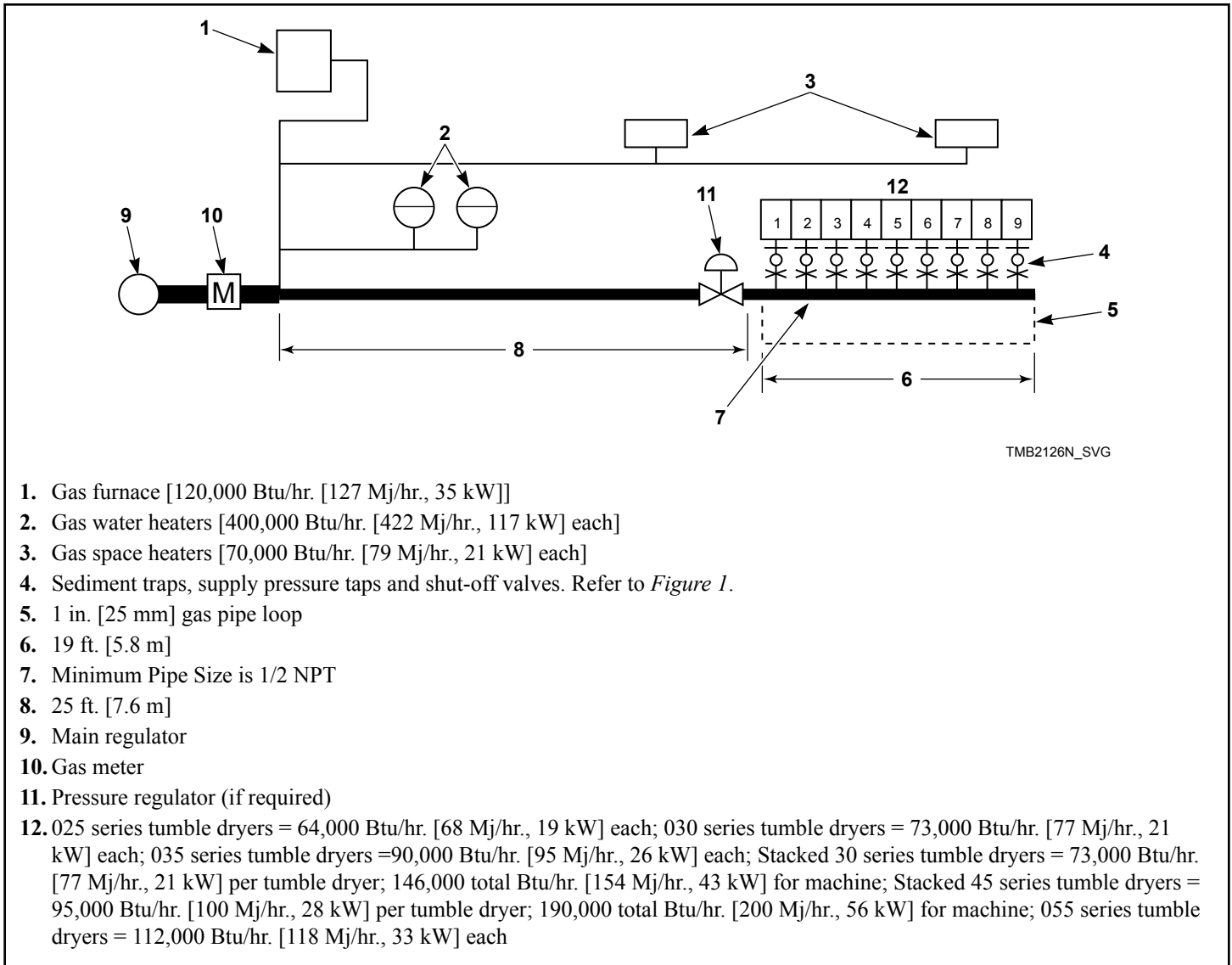

Figure 22

SAMPLE CALCULATIONS:

Equivalent length = Total length of main gas supply pipe to the far end of the tumble dryers.

= 25 ft. + 19 ft. [7.6 m + 5.8 m] gas supply pipe

= 44 ft. [13.4 m] Total Gas Line

Total Btu/hr. = The sum of the Btu/hr. of all 030 series tumble dryers being fed by the main gas supply pipe.

= 9 x 73,000 [77, 21]

= 657,000 Btu/hr. [193 kW]

Using *Table 16*, the main supply pipe diameter should be 2 NPT.

IMPORTANT: Gas loop piping must be installed as illustrated to equalize gas pressure for all tumble dryers connected to single gas service. Other gas using appliances should be connected upstream from loop.

Low Pressure Gas Pipe Sizes

NOTE: Sizing calculations based on National Fuel Gas Code.

Gas Pipe Size Required for 1000 BTU Natural Gas (Standard Conditions) at Upstream Pressure— 7.0 ± 1.5 inches water column pressure [17.4 ± 4.0 mbar, 1.74 ± 0.37 kPa]						
Gas Appli- ances Total BTU/hr.	Equivalent Length					
	25 feet [7.6 m]	50 feet [15.2 m]	75 feet [22.9 m]	100 feet [30 m]	125 feet [38 m]	150 feet [46 m]
	Based on 0.3 inches Water Column Pressure Drop for Length Given Sizes shown in Gas Pipe Nominal Size (NPT)					
100,000	3/4	3/4	3/4	1	1	1
120,000	3/4	3/4	1	1	1	1
140,000	3/4	1	1	1	1	1
160,000	3/4	1	1	1	1-1/4	1-1/4
180,000	3/4	1	1	1-1/4	1-1/4	1-1/4
200,000	1	1	1	1-1/4	1-1/4	1-1/4
300,000	1	1-1/4	1-1/4	1-1/4	1-1/2	1-1/2
400,000	1-1/4	1-1/4	1-1/2	1-1/2	1-1/2	1-1/2
500,000	1-1/4	1-1/2	1-1/2	1-1/2	1-1/2	2
600,000	1-1/4	1-1/2	1-1/2	2	2	2
700,000	1-1/2	1-1/2	2	2	2	2
800,000	1-1/2	1-1/2	2	2	2	2
900,000	1-1/2	2	2	2	2	2-1/2
1,000,000	1-1/2	2	2	2	2-1/2	2-1/2
1,100,000	1-1/2	2	2	2	2-1/2	2-1/2
1,200,000	1-1/2	2	2	2-1/2	2-1/2	2-1/2
1,300,000	2	2	2-1/2	2-1/2	2-1/2	2-1/2
1,400,000	2	2	2-1/2	2-1/2	2-1/2	2-1/2
1,500,000	2	2	2-1/2	2-1/2	2-1/2	2-1/2
1,600,000	2	2	2-1/2	2-1/2	2-1/2	3

Table 16 *continues...*

Gas Pipe Size Required for 1000 BTU Natural Gas (Standard Conditions) at Upstream Pressure— 7.0 ± 1.5 inches water column pressure [17.4 ± 4.0 mbar, 1.74 ± 0.37 kPa]						
Gas Appliances Total BTU/hr.	Equivalent Length					
	25 feet [7.6 m]	50 feet [15.2 m]	75 feet [22.9 m]	100 feet [30 m]	125 feet [38 m]	150 feet [46 m]
	Based on 0.3 inches Water Column Pressure Drop for Length Given Sizes shown in Gas Pipe Nominal Size (NPT)					
1,700,000	2	2-1/2	2-1/2	2-1/2	3	3
1,800,000	2	2-1/2	2-1/2	2-1/2	3	3
1,900,000	2	2-1/2	2-1/2	3	3	3
2,000,000	2	2-1/2	2-1/2	3	3	3
2,200,000	2	2-1/2	3	3	3	3
2,400,000	2-1/2	2-1/2	3	3	3	3-1/2
2,600,000	2-1/2	2-1/2	3	3	3-1/2	3-1/2
2,800,000	2-1/2	3	3	3	3-1/2	3-1/2
3,000,000	2-1/2	3	3	3-1/2	3-1/2	3-1/2
For L.P. Gas, correct the total Btu/hr by multiplying it by 0.6. The answer is the equivalent Btu on the above chart.						

Table 16

High Pressure Gas Pipe Sizes

NOTE: Sizing calculations based on National Fuel Gas Code.

IMPORTANT: A high pressure regulator is required at each machine.

Gas Pipe Size Required for 1000 BTU Natural Gas (Standard Conditions) at Upstream Pressure — 2.0 ± 0.4 PSI [138 ± 28 mbar, 13.7 ± 2.7 kPa]						
Gas Appli- ances Total BTU/hr.	Equivalent Length					
	25 feet [7.6 m]	50 feet [15.2 m]	75 feet [22.9 m]	100 feet [30 m]	125 feet [38 m]	150 feet [46 m]
	Based on 1 PSI Pressure Drop for Length Given Sizes shown in Gas Pipe Nominal Size (NPT)					
100,000	1/2	1/2	1/2	1/2	1/2	1/2
120,000	1/2	1/2	1/2	1/2	1/2	1/2
140,000	1/2	1/2	1/2	1/2	1/2	1/2
160,000	1/2	1/2	1/2	1/2	1/2	1/2
180,000	1/2	1/2	1/2	1/2	1/2	1/2
200,000	1/2	1/2	1/2	1/2	1/2	1/2
300,000	1/2	1/2	1/2	1/2	1/2	3/4
400,000	1/2	1/2	1/2	1/2	1/2	3/4
500,000	1/2	1/2	1/2	3/4	3/4	3/4
600,000	1/2	1/2	3/4	3/4	3/4	3/4
700,000	1/2	3/4	3/4	3/4	3/4	1
800,000	1/2	3/4	3/4	3/4	3/4	1
900,000	1/2	3/4	3/4	3/4	3/4	1
1,000,000	3/4	3/4	3/4	3/4	1	1
1,100,000	3/4	3/4	3/4	3/4	1	1
1,200,000	3/4	3/4	3/4	1	1	1
1,300,000	3/4	3/4	3/4	1	1	1-1/4
1,400,000	3/4	3/4	1	1	1	1-1/2
1,500,000	3/4	3/4	1	1	1	1-1/4
1,600,000	3/4	3/4	1	1	1	1-1/4

Table 17 continues...

Gas Pipe Size Required for 1000 BTU Natural Gas (Standard Conditions) at Upstream Pressure — 2.0 ± 0.4 PSI [138 ± 28 mbar, 13.7 ± 2.7 kPa]						
Gas Appliances Total BTU/hr.	Equivalent Length					
	25 feet [7.6 m]	50 feet [15.2 m]	75 feet [22.9 m]	100 feet [30 m]	125 feet [38 m]	150 feet [46 m]
	Based on 1 PSI Pressure Drop for Length Given Sizes shown in Gas Pipe Nominal Size (NPT)					
1,700,000	3/4	1	1	1	1	1-1/4
1,800,000	3/4	1	1	1	1	1-1/4
1,900,000	3/4	1	1	1	1	1-1/4
2,000,000	3/4	1	1	1	1-1/4	1-1/4
2,200,000	3/4	1	1	1-1/4	1-1/4	1-1/4
2,400,000	1	1	1	1-1/4	1-1/4	1-1/2
2,600,000	1	1	1-1/4	1-1/4	1-1/4	1-1/2
2,800,000	1	1	1-1/4	1-1/4	1-1/4	1-1/2
3,000,000	1	1	1-1/4	1-1/4	1-1/4	1-1/2
For L.P. Gas, correct the total Btu/hr by multiplying it by 0.6. The answer is the equivalent Btu on the above chart.						

Table 17

High Altitude Burner Orifice Sizing

For proper operation at altitudes above 2,000 feet [610 m], the gas burner orifice size must be reduced to ensure complete com-

bustion. Heat input derate of 4% per 1,000 feet [305 meters] of altitude above sea level. Refer to *Table 18* or *Table 19*.

For IEC models, consult local gas supplier.

Standard Line Models

Model	Market	Gas	Altitude	Burner Orifice			
			feet [meters]	No.	inches [mm]	Quantity	Part No.
025 Series	T, G, A, H, J, K, R, U	Natural Gas	2,001-4,000 [610-1,220]	27	0.1440 [3.66]	1	70684135
			4,001-6,000 [1,221-1,830]	28	0.1405 [3.57]		70684134
			6,001-8,000 [1,831-2,440]	29	0.1360 [3.45]		70684132
			8,001-10,000 [2,441-3,050]	3.3 mm	0.1299 [3.30]		70684130
	T, G, A, H, R	L.P. Gas	2,001-4,000 [610-1,220]	44	0.0860 [2.18]		70684110
			4,001-6,000 [1,221-1,830]	45	0.0820 [2.08]		70684109
			6,001-8,000 [1,831-2,440]	46	0.0810 [2.06]		70684108
			8,001-10,000 [2,441-3,050]	48	0.0760 [1.93]		70684106
	U	L.P. Gas	2,001-4,000 [610-1,220]	48	0.0760 [1.93]		70684106
			4,001-6,000 [1,221-1,830]	48	0.0760 [1.93]		70684106
			6,001-8,000 [1,831-2,440]	49	0.0730 [1.85]		70684105
			8,001-10,000 [2,441-3,050]	50	0.0700 [1.78]		70684104
	J	L.P. Gas	2,001-4,000 [610-1,220]	48	0.0760 [1.93]		70684106
			4,001-6,000 [1,221-1,830]	48	0.0760 [1.93]		70684106
			6,001-8,000 [1,831-2,440]	49	0.0730 [1.85]		70684105
			8,001-10,000 [2,441-3,050]	50	0.0700 [1.78]		70684104

Table 18 *continues...*

Model	Market	Gas	Altitude	Burner Orifice			
			feet [meters]	No.	inches [mm]	Quantity	Part No.
030 Series	T, G, A, H, J, K, R, U	Natural Gas	2,001-4,000 [610-1,220]	23	0.1540 [3.91]	1	70684139
			4,001-6,000 [1,221-1,830]	25	0.1495 [3.80]		70684137
			6,001-8,000 [1,831-2,440]	27	0.1440 [3.66]		70684135
			8,001-10,000 [2,441-3,050]	3.50 mm	0.1378 [3.50]		70684133
	T, G, A, H, R	L.P. Gas	2,001-4,000 [610-1,220]	42	0.0935 [2.37]		70684114
			4,001-6,000 [1,221-1,830]	2.30 mm	0.0906 [2.30]		70684113
			6,001-8,000 [1,831-2,440]	2.20 mm	0.0866 [2.20]		70684111
			8,001-10,000 [2,441-3,050]	45	0.0820 [2.08]		70684109
	U	L.P. Gas	2,001-4,000 [610-1,220]	45	0.0820 [2.08]		70684109
			4,001-6,000 [1,221-1,830]	47	0.0785 [1.99]		70684107
			6,001-8,000 [1,831-2,440]	48	0.0760 [1.93]		70684106
			8,001-10,000 [2,441-3,050]	49	0.0730 [1.85]		70684105
	J	L.P. Gas	2,001-4,000 [610-1,220]	45	0.0820 [2.08]		70684109
			4,001-6,000 [1,221-1,830]	46	0.0810 [2.06]		70684108
			6,001-8,000 [1,831-2,440]	48	0.0760 [1.93]		70684106
			8,001-10,000 [2,441-3,050]	49	0.0730 [1.85]		70684105

Table 18 continues...

Model	Market	Gas	Altitude	Burner Orifice			
			feet [meters]	No.	inches [mm]	Quantity	Part No.
T30 Series	T, G, A, H, J, K, R, U	Natural Gas	2,001-4,000 [610-1,220]	23	0.1540 [3.91]	2	70684139
			4,001-6,000 [1,221-1,830]	25	0.1495 [3.80]		70684137
			6,001-8,000 [1,831-2,440]	27	0.1440 [3.66]		70684135
			8,001-10,000 [2,441-3,050]	3.50 mm	0.1378 [3.50]		70684133
	T, G, A, H, R	L.P. Gas	2,001-4,000 [610-1,220]	42	0.0935 [2.37]		70684114
			4,001-6,000 [1,221-1,830]	2.30 mm	0.0906 [2.30]		70684113
			6,001-8,000 [1,831-2,440]	2.20 mm	0.0866 [2.20]		70684111
			8,001-10,000 [2,441-3,050]	45	0.0820 [2.08]		70684109
	U	L.P. Gas	2,001-4,000 [610-1,220]	45	0.0820 [2.08]		70684109
			4,001-6,000 [1,221-1,830]	47	0.0785 [1.99]		70684107
			6,001-8,000 [1,831-2,440]	48	0.0760 [1.93]		70684106
			8,001-10,000 [2,441-3,050]	49	0.0730 [1.85]		70684105
	J	L.P. Gas	2,001-4,000 [610-1,220]	45	0.0820 [2.08]		70684109
			4,001-6,000 [1,221-1,830]	46	0.0810 [2.06]		70684108
			6,001-8,000 [1,831-2,440]	48	0.0760 [1.93]		70684106
			8,001-10,000 [2,441-3,050]	49	0.0730 [1.85]		70684105

Table 18 *continues...*

Model	Market	Gas	Altitude	Burner Orifice			
			feet [meters]	No.	inches [mm]	Quantity	Part No.
035 Series	T, G, A, H, J, K, R, U	Natural Gas	2,001-4,000 [610-1,220]	11/64	0.1719 [4.37]	1	70684145
			4,001-6,000 [1,221-1,830]	19	0.1660 [4.22]		70684143
			6,001-8,000 [1,831-2,440]	20	0.1610 [4.09]		70684142
			8,001-10,000 [2,441-3,050]	23	0.1510 [3.91]		70684139
	T, G, A, H, R	L.P. Gas	2,001-4,000 [610-1,220]	36	0.1065 [2.71]		70684120
			4,001-6,000 [1,221-1,830]	38	0.1015 [2.58]		70684118
			6,001-8,000 [1,831-2,440]	40	0.0980 [2.49]		70684116
			8,001-10,000 [2,441-3,050]	42	0.0935 [2.37]		70684114
	U	L.P. Gas	2,001-4,000 [610-1,220]	42	0.0935 [2.37]		70684114
			4,001-6,000 [1,221-1,830]	2.3 mm	0.0906 [2.30]		70684113
			6,001-8,000 [1,831-2,440]	2.2 mm	0.0866 [2.20]		70684111
			8,001-10,000 [2,441-3,050]	45	0.0820 [2.08]		70684109
	J	L.P. Gas	2,001-4,000 [610-1,220]	42	0.0935 [2.37]		70684114
			4,001-6,000 [1,221-1,830]	2.3 mm	0.0906 [2.30]		70684113
			6,001-8,000 [1,831-2,440]	43	0.0890 [2.26]		70684112
			8,001-10,000 [2,441-3,050]	44	0.0860 [2.18]		70684110

Table 18 continues...

Model	Market	Gas	Altitude	Burner Orifice			
			feet [meters]	No.	inches [mm]	Quantity	Part No.
T45 Series	T, G, A, H, J, K, R, U	Natural Gas	2,001-4,000 [610-1,220]	17	0.1730 [4.39]	2	70684146
			4,001-6,000 [1,221-1,830]	18	0.1695 [4.31]		70684144
			6,001-8,000 [1,831-2,440]	20	0.1610 [4.09]		70684142
			8,001-10,000 [2,441-3,050]	23	0.1510 [3.91]		70684139
	T, G, H, R	L.P. Gas	2,001-4,000 [610-1,220]	36	0.1065 [2.71]		70684120
			4,001-6,000 [1,221-1,830]	38	0.1015 [2.58]		70684118
			6,001-8,000 [1,831-2,440]	40	0.0980 [2.49]		70684116
			8,001-10,000 [2,441-3,050]	42	0.0935 [2.37]		70684114
	U	L.P. Gas	2,001-4,000 [610-1,220]	45	0.0820 [2.08]		70684109
			4,001-6,000 [1,221-1,830]	47	0.0785 [1.99]		70684107
			6,001-8,000 [1,831-2,440]	48	0.0760 [1.93]		70684106
			8,001-10,000 [2,441-3,050]	49	0.0730 [1.85]		70684105
	A	L.P. Gas	2,001-4,000 [610-1,220]	38	0.1015 [2.58]		70684118
			4,001-6,000 [1,221-1,830]	40	0.0980 [2.49]		70684116
			6,001-8,000 [1,831-2,440]	42	0.0935 [2.37]		70684114
			8,001-10,000 [2,441-3,050]	2.3 mm	0.0906 [2.30]		70684113
	J	L.P. Gas	2,001-4,000 [610-1,220]	42	0.0935 [2.37]		70684114
			4,001-6,000 [1,221-1,830]	2.3 mm	0.0906 [2.30]		70684113
			6,001-8,000 [1,831-2,440]	43	0.0890 [2.26]		70684112
			8,001-10,000	44	0.0860		70684110

Model	Market	Gas	Altitude	Burner Orifice			
			feet [meters]	No.	inches [mm]	Quantity	Part No.
055 Series	T, G, A, H, J, K, R, U	Natural Gas	2,001-4,000 [610-1,220]	13	0.1850 [4.70]	1	70684150
			4,001-6,000 [1,221-1,830]	15	0.1800 [4.57]		70684148
			6,001-8,000 [1,831-2,440]	17	0.1730 [4.39]		70684146
			8,001-10,000 [2,441-3,050]	19	0.1660 [4.22]		70684143
	T, G, A, H, R	L.P. Gas	2,001-4,000 [610-1,220]	33	0.1130 [2.87]		70684124
			4,001-6,000 [1,221-1,830]	34	0.1110 [2.82]		70684123
			6,001-8,000 [1,831-2,440]	36	0.1065 [2.71]		70684120
			8,001-10,000 [2,441-3,050]	38	0.1015 [2.58]		70684118
	U	L.P. Gas	2,001-4,000 [610-1,220]	44	0.0860 [2.18]		70684110
			4,001-6,000 [1,221-1,830]	45	0.0820 [2.08]		70684109
			6,001-8,000 [1,831-2,440]	46	0.0810 [2.06]		70684108
			8,001-10,000 [2,441-3,050]	48	0.0760 [1.93]		70684106
	J	L.P. Gas	2,001-4,000 [610-1,220]	38	0.1015 [2.58]		70684118
			4,001-6,000 [1,221-1,830]	40	0.0980 [2.49]		70684116
			6,001-8,000 [1,831-2,440]	42	0.0935 [2.37]		70684114
			8,001-10,000 [2,441-3,050]	2.3 mm	0.0906 [2.30]		70684113

Table 18

Eco Line Models (only available in Natural Gas)

Model	Gas	Altitude	Burner Orifice			
		feet [meters]	No.	inches [mm]	Quantity	Part No.
025 Series	Natural Gas	2,001-4,000 [610-1,220]	3.40 mm	0.1339 [3.40]	1	70684131
		4,001-6,000 [1,221-1,830]	3.30 mm	0.1299 [3.30]		70684130
		6,001-8,000 [1,831-2,440]	1/8	0.1250 [3.18]		70684128
		8,001-10,000 [2,441-3,050]	31	0.1200 [3.05]		70684126
030 Series	Natural Gas	2,001-4,000 [610-1,220]	3.40 mm	0.1339 [3.40]	1	70684131
		4,001-6,000 [1,221-1,830]	3.30 mm	0.1299 [3.30]		70684130
		6,001-8,000 [1,831-2,440]	1/8	0.1250 [3.18]		70684128
		8,001-10,000 [2,441-3,050]	31	0.1200 [3.05]		70684126
T30 Series	Natural Gas	2,001-4,000 [610-1,220]	3.30 mm	0.1299 [3.30]	2	70684130
		4,001-6,000 [1,221-1,830]	1/8	0.1250 [3.18]		70684128
		6,001-8,000 [1,831-2,440]	31	0.1200 [3.05]		70684126
		8,001-10,000 [2,441-3,050]	32	0.1160 [2.95]		70684125
035 Series	Natural Gas	2,001-4,000 [610-1,220]	26	0.1470 [3.73]	1	70684136
		4,001-6,000 [1,221-1,830]	28	0.1405 [3.57]		70684134
		6,001-8,000 [1,831-2,440]	3.50 mm	0.1378 [3.50]		70684133
		8,001-10,000 [2,441-3,050]	3.30 mm	0.1299 [3.30]		70684130

Table 19 *continues...*

Gas Requirements

Model	Gas	Altitude	Burner Orifice			
		feet [meters]	No.	inches [mm]	Quantity	Part No.
T45 Series	Natural Gas	2,001-4,000 [610-1,220]	22	0.1570 [3.99]	2	70684140
		4,001-6,000 [1,221-1,830]	23	0.1540 [3.91]		70684139
		6,001-8,000 [1,831-2,440]	26	0.1470 [3.73]		70684136
		8,001-10,000 [2,441-3,050]	28	0.1405 [3.57]		70684134
055 Series	Natural Gas	2,001-4,000 [610-1,220]	14	0.1820 [4.62]	1	70684149
		4,001-6,000 [1,221-1,830]	16	0.1770 [4.50]		70684147
		6,001-8,000 [1,831-2,440]	18	0.1695 [4.31]		70684144
		8,001-10,000 [2,441-3,050]	20	0.1610 [4.09]		70684142

Table 19

Electrical Requirements

Electrical Requirements

	WARNING
<ul style="list-style-type: none"> To reduce the risk of electric shock, disconnect this appliance from the power supply before attempting any user maintenance other than cleaning the lint trap for dryers. Turning the controls to the OFF position does not disconnect this appliance from the power supply. To reduce the risk of fire and electric shock, check with a qualified service person for proper grounding procedures. Improper connection of the equipment grounding conductor may result in a risk of electric shock. Certain internal parts are intentionally not grounded and may present a risk of electric shock only during servicing. Service Personnel - Do not contact the following parts while the appliance is energized: Input/Output Board and Variable Frequency Drive, including the heat sinks. This appliance shall be installed in accordance with the rules in force, and dryers used only in a sufficiently ventilated space. Consult technical instruction before installation and use of this appliance. 	
W935	

	CAUTION
<p>Outside of Europe, to reduce the risk of injury or component failure, if electrical supply is coming from a three phase service, DO NOT connect a "High Leg" or "Stinger Leg" to a single phase machine. On a three phase machine, if there is a "High Leg" or "Stinger Leg" it should be connected to L3.</p>	
W938	

	WARNING
<p>The appliance must not be supplied through an external switching device, such as a timer, or connected to a circuit that is regularly switched on and off by a utility.</p>	
W943	

IMPORTANT: Electrical connections must be made by a qualified electrician using data on serial plate, installation manuals and wiring diagram provided with tumble dryer and according to local codes. Install a circuit breaker as close to the tumble dryer as possible. If more than one tumble dryer is being installed, a circuit breaker must be provided for each.

NOTE: Connect tumble dryer to an individual branch circuit not shared with lighting or other equipment.

NOTE: 3 Phase Tumble Dryers Only - Do not use fuses to avoid the possibility of "single phasing" and causing premature failure of the motors.

	WARNING
<p>In case of servicing (or putting the tumble dryer out of order), disconnect the tumble dryer from the main supply by switching off the circuit breaker.</p>	
W796	

Wiring Diagram

NOTE: Wiring diagram location: inside electrical box.

The wiring diagram part number is in the lower portion of the electrical data on the serial plate.

Wiring for Central Pay

Applicable for the following control suffixes (position 7 and 8 of the model number): BL, NL, VL and WL.

IMPORTANT: Tumble dryers may have one of two types of central pay configurations: a 12vDC self-contained version or an unpowered version requiring a customer-supplied power source and resistor. Refer to Central Pay Option diagram provided with tumble dryer for specifications. Incorrect application may cause component damage.

System Connections

Connection to central pay systems will be made in the rear junction box of the tumble dryer. For T30 and T45 models, connection for both the lower control and upper control will be made in the upper junction box.

Locate the harness with Black, Red, White with Red Stripe and Orange with Black Stripe wires. For T30 and T45 models, the upper and lower harness can be identified by a yellow label on the harness tubing indicating "UPPER" and a white label on the harness tubing indicating "LOWER".

Electrical Requirements

The wire colors will be the same regardless of control type. Splice the after-market central pay system wires to the tumble dryer control wire harness as follows.

Wire Colors	Description
Red	Start Pulse Signal Input
Black	Start Pulse Signal Input
White with Red Stripe	"Machine Available" Signal Output
Orange with Black Stripe	"Machine Available" Signal Output

Start Pulse Requirements

All control types will consider a pulse valid if it is between 10 and 1000 milliseconds in length, with a minimum of 25 milliseconds between pulses.

Grounding Instructions

NOTE: To ensure protection against shock, this machine **MUST** be electrically grounded in accordance with the local codes, or in the absence of local codes, with the latest edition of the National Electrical Code ANSI/NFPA No. 70. In Canada the electrical connections are to be made in accordance with CSA C22.1 latest edition Canadian Electrical Code, or local codes. Electrical work should be done by a qualified electrician.

This machine must be grounded. In the event of malfunction or breakdown, grounding will reduce the risk of electric shock by providing a path of least resistance for electric current. This machine must be connected to a grounded metal, permanent wiring system; or an equipment grounding conductor must be run with

Service/Ground Location



Model	Heat Source	Ground and Terminal Block Locations
025 030 035 055 (gas only)	Gas/steam, low voltage Gas/steam, high voltage	 <p style="text-align: right; margin-right: 50px;">TMB2610N_SVG</p> <ol style="list-style-type: none"> 1. Ground 2. Power Distribution Block

Table continues...

the circuit conductors and connected to the appropriate ground location.

- Metal conduit and/or BX cable is not considered ground.
- Connecting the Neutral from the electrical service box to the tumble dryer ground screw does not constitute a ground.
- A dedicated ground conduit (wire) must be connected between the electrical service box ground bar and machine ground screw.

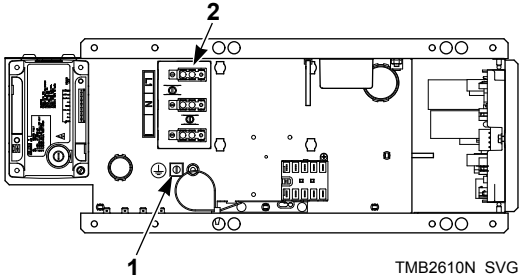
	<h2>WARNING</h2>
<p>To reduce the risk of electrical shock, de-energize the electrical circuit being connected to the tumble dryer before making any electrical connections. All electrical connections should be made by a qualified electrician. Never attempt to connect a live circuit.</p>	
W409R1	

	<h2>CAUTION</h2>
<p>Label all wires prior to disconnection when servicing controls. Wiring errors can cause improper and dangerous operation. Verify proper operation after servicing.</p>	
W071	

For On Premises Laundry (OPL) Models Only

IEC OPL (non-vend) models are factory-equipped with an emergency stop button on the front panel.

NOTE: Activation of the emergency stop switch stops all tumble dryer control circuit functions, but **DOES NOT** remove all electrical power from tumble dryer.

Model	Heat Source	Ground and Terminal Block Locations
025 030 035 055	Electric, low voltage Electric, high voltage	 <p style="text-align: center;">TMB2614N_SVG</p> <ol style="list-style-type: none"> 1. Ground 2. Power Distribution Block
T30 T45 (gas only)	Gas/Steam, low voltage Gas/Steam, high voltage	 <p style="text-align: center;">TMB2616N_SVG</p> <p>NOTE: Connection only required in upper junction box.</p> <ol style="list-style-type: none"> 1. Ground 2. Power Distribution Block

Table continues...

Model	Heat Source	Ground and Terminal Block Locations
T30	Electric, low voltage Electric, high voltage	 <p style="text-align: center;">TMB2620N_SVG</p> <p>NOTE: Connection required in upper and lower junction boxes.</p> <ol style="list-style-type: none"> 1. Ground 2. Power Distribution Block

To Connect Electrical Service To Machine

NOTE: All machines require separate service connections for each upper and lower unit. Serial Plate ratings reflect current draw, breaker rating and conductor size recommendations per unit.

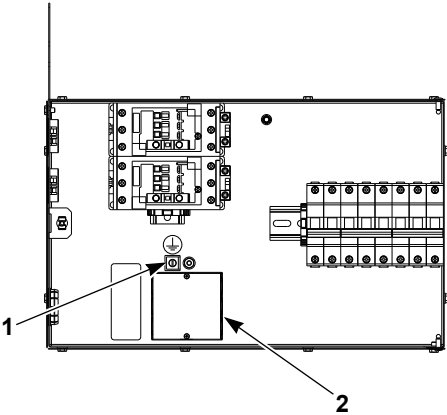
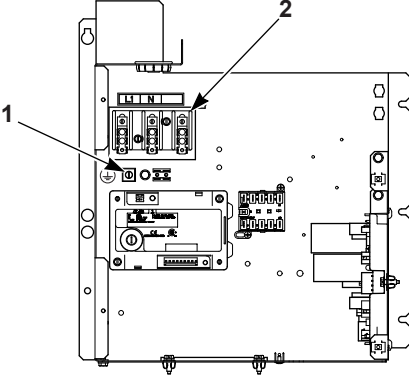
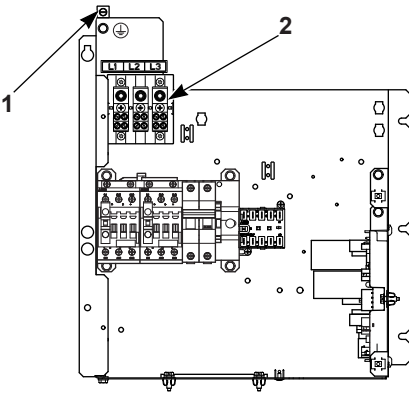
The following steps outline the procedure for connecting electrical service to the machine.

- 3 Phase Models – Each machine must be connected to its own individual branch circuit breaker, not fuses, to avoid the possibility of “single phasing” and causing premature failure of the motor(s).
- Electrical service must be connected using the appropriate permanent rigid metal conduit system.
- Service conductors must be copper only.

For an existing service, determine your service voltage and conductor amperage. Carefully review the machine serial plate ratings and Electrical Requirements section of this manual. If service is inadequate it must be upgraded by a qualified electrical contractor. Never connect an improper or inadequate service to any machine.

NOTE: The wiring diagram is located inside the junction or contactor box.

1. For new service, install a circuit breaker of proper voltage and current rating as close to each machine as possible.
2. Route service conduit from service breaker panel to machine service connection box. Conduit routing should not obstruct access for maintenance or servicing. Refer to Service/Ground Location.

3. Pull conductors through conduit and attach to circuit breaker and ground connection. Secure service ground wire to the machine grounding screw or lug. Attach service conductors to appropriately labeled positions on the machine terminal block. Make sure all connections are secure.

Electrical Connections for T30 and T45 Only

All gas tumble dryers require a single service connection to TB1 of the upper unit junction box only. The serial plate reflects current draw, breaker rating and conductor size recommendations for the entire machine.

All electric tumble dryers require separate service connections for each upper and lower unit. Serial Plate ratings reflect current draw, breaker rating and conductor size recommendations per unit.

Configuring Your Tumble Dryer for Other Service Voltages

NOTE: Tumble dryers are not field convertible and must be connected to service specified on serial plate.

Electrical Specifications

NOTE: Wire sizes were obtained from the Canadian Electrical Code for 75 C. wire and are intended for use as a guideline only. Electrical connections should be made by a qualified electrical contractor in accordance with all applicable local and national requirements.

NOTE: Electrical specifications below are subject to change without notice. Always refer to product serial plate for most current specifications of product being installed.

	CAUTION
<p>Use copper conductors only with the following rating when wiring appliance to electric supply: Dryer gas and steam heat models require 187°F (75°C) minimum. Dryer electric heat models require 194°F (90°C) minimum.</p>	
W936	

NOTE: Connect this appliance to an individual branch circuit.

NOTE: 3 Phase Only – Each tumble dryer must be connected to its own individual branch circuit breaker, not fuses, to avoid the possibility of “single phasing” and causing premature failure of the motor(s).

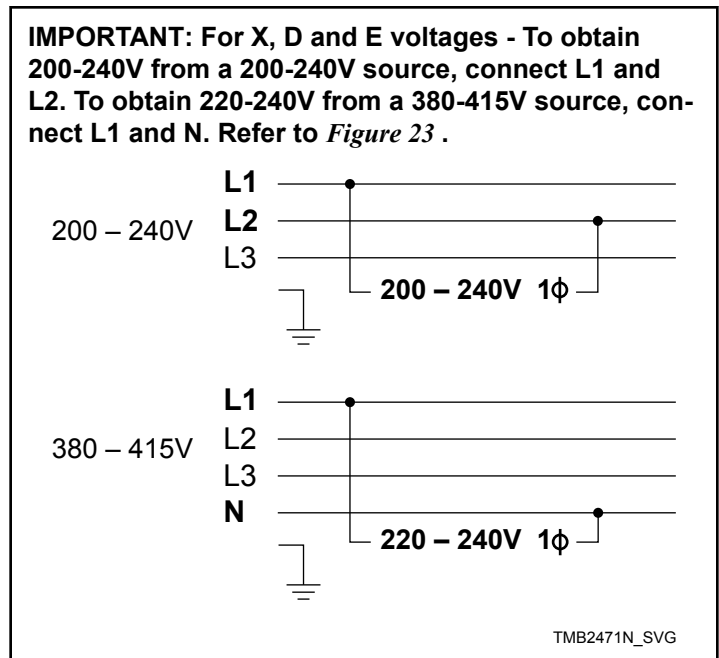

Figure 23

025, 030 and 035 Series Gas and Steam Models

Voltage Code	Voltage	Cycle	Phase	Wire	Full Load Amps	Recommended Circuit Breaker Rating Amps	Wire Size AWG [mm ²]
B	100-120	50-60	1	L1, Neutral, and ground	10	15	14 [2.5]
X	200-240	50-60	1-3	Refer to <i>Figure 23</i>	6	15	14 [2.5]
N	440-480	50-60	3	L1, L2, L3 and ground	3	15	14 [2.5]
P	380-415	50-60	3	L1, L2, L3 and ground	3	15	14 [2.5]

Table 20

055 Series Gas Models

Voltage Code	Voltage	Cycle	Phase	Wire	Full Load Amps	Recommended Circuit Breaker Rating Amps	Wire Size AWG [mm ²]
B	100-120	50-60	1	L1, Neutral, and ground	12	15	14 [2.5]

Table 21 *continues...*

Electrical Requirements

X	200-240	50-60	1-3	Refer to <i>Figure 23</i>	7	15	14 [2.5]
N	440-480	50-60	3	L1, L2, L3 and ground	3	15	14 [2.5]
P	380-415	50-60	3	L1, L2, L3 and ground	3	15	14 [2.5]

Table 21

T30 Series Gas and Steam Models (Total Machine)

Voltage Code	Voltage	Cycle	Phase	Wire	Full Load Amps	Recommended Circuit Breaker Rating Amps	Wire Size AWG [mm ²]
B	100-120	50-60	1	L1, Neutral, and ground	16	20	12 [4]
X	200-240	50-60	1-3	Refer to <i>Figure 23</i>	9	15	14 [2.5]
N	440-480	50-60	3	L1, L2, L3 and ground	6	15	14 [2.5]
P	380-415	50-60	3	L1, L2, L3 and ground	6	15	14 [2.5]

Table 22

T45 Series Gas Models (Total Machine)

Voltage Code	Voltage	Cycle	Phase	Wire	Full Load Amps	Recommended Circuit Breaker Rating Amps	Wire Size AWG [mm ²]
X	200-240	50-60	1-3	Refer to <i>Figure 23</i>	12	15	14 [2.5]
N	440-480	50-60	3	L1, L2, L3 and ground	6	15	14 [2.5]
P	380-415	50-60	3	L1, L2, L3 and ground	6	15	14 [2.5]

Table 23

9 kW Eco Line 025 Series Electric Models

Voltage Code	Voltage	Cycle	Phase	Wire	Full Load Amps	Recommended Circuit Breaker Rating Amps	Wire Size AWG [mm ²]
D	200-208	50-60	1	Refer to <i>Figure 23</i>	46	60	6 [16]
E	230-240	50-60	1	Refer to <i>Figure 23</i>	40	50	8 [10]
F	200-208	50-60	3	L1, L2, L3 and ground	28	35	8 [10]
G	230-240	50-60	3	L1, L2, L3 and ground	24	30	10 [6]
H	380	50-60	3	L1, L2, L3 and ground	15	20	12 [4]
J	400-415	50-60	3	L1, L2, L3 and ground	13	20	12 [4]
K	440	50-60	3	L1, L2, L3 and ground	13	20	12 [4]
L	460-480	50-60	3	L1, L2, L3 and ground	12	15	14 [2.5]

Table 24

12 kW 025 Series Electric Models

Voltage Code	Voltage	Cycle	Phase	Wire	Full Load Amps	Recommended Circuit Breaker Rating Amps	Wire Size AWG [mm ²]
D	200-208	50-60	1	Refer to <i>Figure 23</i>	60	80	4 [25]
E	230-240	50-60	1	Refer to <i>Figure 23</i>	53	70	4 [25]
F	200-208	50-60	3	L1, L2, L3 and ground	36	45	8 [10]
G	230-240	50-60	3	L1, L2, L3 and ground	32	40	8 [10]
H	380	50-60	3	L1, L2, L3 and ground	19	25	10 [6]

Table 25 continues...

Electrical Requirements

J	400-415	50-60	3	L1, L2, L3 and ground	18	25	10 [6]
K	440	50-60	3	L1, L2, L3 and ground	17	25	10 [6]
L	460-480	50-60	3	L1, L2, L3 and ground	15	20	12 [4]

Table 25

21 kW Standard Line 030 Series Electric Models

Voltage Code	Voltage	Cycle	Phase	Wire	Full Load Amps	Recommended Circuit Breaker Rating Amps	Wire Size AWG [mm ²]
D	200-208	50-60	1	Refer to <i>Figure 23</i>	104	150	1/0 [50]
E	230-240	50-60	1	Refer to <i>Figure 23</i>	90	125	1 [35]
F	200-208	50-60	3	L1, L2, L3 and ground	61	80	4 [25]
G	230-240	50-60	3	L1, L2, L3 and ground	52	70	4 [25]
H	380	50-60	3	L1, L2, L3 and ground	33	45	8 [10]
J	400-415	50-60	3	L1, L2, L3 and ground	30	40	8 [10]
K	440	50-60	3	L1, L2, L3 and ground	29	40	8 [10]
L	460-480	50-60	3	L1, L2, L3 and ground	27	35	8 [10]

Table 26

12 kW Eco Line 030 Series Electric Models

Voltage Code	Voltage	Cycle	Phase	Wire	Full Load Amps	Recommended Circuit Breaker Rating Amps	Wire Size AWG [mm ²]
--------------	---------	-------	-------	------	----------------	---	----------------------------------

Table 27 continues...

D	200-208	50-60	1	Refer to <i>Figure 23</i>	60	80	4 [25]
E	230-240	50-60	1	Refer to <i>Figure 23</i>	53	70	4 [25]
F	200-208	50-60	3	L1, L2, L3 and ground	37	50	8 [10]
G	230-240	50-60	3	L1, L2, L3 and ground	33	45	8 [10]
H	380	50-60	3	L1, L2, L3 and ground	20	25	10 [6]
J	400-415	50-60	3	L1, L2, L3 and ground	18	25	10 [6]
K	440	50-60	3	L1, L2, L3 and ground	17	25	10 [6]
L	460-480	50-60	3	L1, L2, L3 and ground	16	20	12 [4]

Table 27

21 kW Standard Line T30 Series Electric Models (Per Pocket)

Voltage Code	Voltage	Cycle	Phase	Wire	Full Load Amps (Per Pocket)	Recommended Circuit Breaker Rating Amps	Wire Size AWG [mm ²]
F	200-208	50-60	3	L1, L2, L3 and ground	61	80	4 [25]
G	230-240	50-60	3	L1, L2, L3 and ground	52	70	4 [25]
H	380	50-60	3	L1, L2, L3 and ground	33	45	8 [10]
J	400-415	50-60	3	L1, L2, L3 and ground	30	40	8 [10]
K	440	50-60	3	L1, L2, L3 and ground	29	40	8 [10]
L	460-480	50-60	3	L1, L2, L3 and ground	27	35	8 [10]

Table 28

12 kW Eco Line T30 Series Electric Models (Per Pocket)

Voltage Code	Voltage	Cycle	Phase	Wire	Full Load Amps	Recommended Circuit Breaker Rating Amps	Wire Size AWG [mm ²]
F	200-208	50-60	3	L1, L2, L3 and ground	37	50	8 [10]
G	230-240	50-60	3	L1, L2, L3 and ground	33	45	8 [10]
H	380	50-60	3	L1, L2, L3 and ground	20	25	10 [6]
J	400-415	50-60	3	L1, L2, L3 and ground	18	25	10 [6]
K	440	50-60	3	L1, L2, L3 and ground	17	25	10 [6]
L	460-480	50-60	3	L1, L2, L3 and ground	16	20	12 [4]

Table 29

24 kW Standard Line 035 Series Electric Models

Voltage Code	Voltage	Cycle	Phase	Wire	Full Load Amps	Recommended Circuit Breaker Rating Amps	Wire Size AWG [mm ²]
D	200-208	50-60	1	Refer to <i>Figure 23</i>	118	150	1/0 [50]
E	230-240	50-60	1	Refer to <i>Figure 23</i>	102	150	1/0 [50]
F	200-208	50-60	3	L1, L2, L3 and ground	69	90	3 [26.7]
G	230-240	50-60	3	L1, L2, L3 and ground	59	80	4 [25]
H	380	50-60	3	L1, L2, L3 and ground	37	50	8 [10]
J	400-415	50-60	3	L1, L2, L3 and ground	34	45	8 [10]
K	440	50-60	3	L1, L2, L3 and ground	32	40	8 [10]

Table 30 *continues...*

L	460-480	50-60	3	L1, L2, L3 and ground	30	40	8 [10]
---	---------	-------	---	--------------------------	----	----	--------

Table 30

12 kW Eco Line 035 Series Electric Models

Voltage Code	Voltage	Cycle	Phase	Wire	Full Load Amps	Recommended Circuit Breaker Rating Amps	Wire Size AWG [mm ²]
D	200-208	50-60	1	Refer to <i>Figure 23</i>	60	80	4 [25]
E	230-240	50-60	1	Refer to <i>Figure 23</i>	52	70	4 [25]
F	200-208	50-60	3	L1, L2, L3 and ground	36	45	8 [10]
G	230-240	50-60	3	L1, L2, L3 and ground	31	40	8 [10]
H	380	50-60	3	L1, L2, L3 and ground	19	25	10 [6]
J	400-415	50-60	3	L1, L2, L3 and ground	18	25	10 [6]
K	440	50-60	3	L1, L2, L3 and ground	17	25	10 [6]
L	460-480	50-60	3	L1, L2, L3 and ground	15	20	12 [4]

Table 31

18 kW Medium 035 Series Electric Models

Voltage Code	Voltage	Cycle	Phase	Wire	Full Load Amps	Recommended Circuit Breaker Rating Amps	Wire Size AWG [mm ²]
D	200-208	50-60	1	Refer to <i>Figure 23</i>	89	125	1 [35]
E	230-240	50-60	1	Refer to <i>Figure 23</i>	77	100	3 [26.7]

Table 32 continues...

Electrical Requirements

F	200-208	50-60	3	L1, L2, L3 and ground	52	70	4 [25]
G	230-240	50-60	3	L1, L2, L3 and ground	46	60	6 [16]
H	380	50-60	3	L1, L2, L3 and ground	28	35	8 [10]
J	400-415	50-60	3	L1, L2, L3 and ground	26	35	8 [10]
K	440	50-60	3	L1, L2, L3 and ground	25	35	8 [10]
L	460-480	50-60	3	L1, L2, L3 and ground	23	30	10 [6]

Table 32

9 kW Low 035 Series Electric Models

Voltage Code	Voltage	Cycle	Phase	Wire	Full Load Amps	Recommended Circuit Breaker Rating Amps	Wire Size AWG [mm ²]
H	380	50-60	3	L1, L2, L3 and ground	15	20	12 [4]
J	400-415	50-60	3	L1, L2, L3 and ground	14	20	12 [4]

Table 33

27 kW Standard Line 055 Series Electric Models

Voltage Code	Voltage	Cycle	Phase	Wire	Full Load Amps	Recommended Circuit Breaker Rating Amps	Wire Size AWG [mm ²]
D	200-208	50-60	1	Refer to <i>Figure 23</i>	133	175	2/0 [70]
E	230-240	50-60	1	Refer to <i>Figure 23</i>	116	150	1/0 [50]
F	200-208	50-60	3	L1, L2, L3 and ground	78	100	3 [26.7]

Table 34 *continues...*

G	230-240	50-60	3	L1, L2, L3 and ground	67	90	3 [26.7]
H	380	50-60	3	L1, L2, L3 and ground	42	60	6 [16]
J	400-415	50-60	3	L1, L2, L3 and ground	39	50	8 [10]
K	440	50-60	3	L1, L2, L3 and ground	37	50	8 [10]
L	460-480	50-60	3	L1, L2, L3 and ground	34	45	8 [10]

Table 34

18 kW Eco Line 055 Series Electric Models

Voltage Code	Voltage	Cycle	Phase	Wire	Full Load Amps	Recommended Circuit Breaker Rating Amps	Wire Size AWG [mm ²]
D	200-208	50-60	1	Refer to <i>Figure 23</i>	90	125	1 [35]
E	230-240	50-60	1	Refer to <i>Figure 23</i>	78	100	3 [26.7]
F	200-208	50-60	3	L1, L2, L3 and ground	53	70	4 [25]
G	230-240	50-60	3	L1, L2, L3 and ground	47	60	6 [16]
H	380	50-60	3	L1, L2, L3 and ground	29	40	8 [10]
J	400-415	50-60	3	L1, L2, L3 and ground	26	35	8 [10]
K	440	50-60	3	L1, L2, L3 and ground	25	35	8 [10]
L	460-480	50-60	3	L1, L2, L3 and ground	23	30	10 [6]

Table 35

Steam Requirements

Steam Requirements



WARNING

This appliance does not contain inherent pressure relief. A pressure relief valve rated for a maximum of 125 psi shall be provided by the steam source.

W942

NOTE: Steam valve and required adapter are located in cylinder or lint compartment.

NOTE: Machines require a constant 80 to 100 psig [5.3 to 6.9 bar] steam service for optimum operation. The maximum allowable steam pressure is 125 psig [8.6 bar]. In no case may the pressure exceed the above value.

Obtain specific steam service pipe sizes from steam system supplier or a qualified steam fitter.

- Refer to *Figure 24* for proper steam pipe configurations.
- To prevent condensate draining from headers to tumble dryer, piping should have a minimum 12 inch [300 mm] rise above respective header. Do not make steam connection to header with a horizontal or downward facing tee or elbow.
- Whenever possible, horizontal runs of steam lines must drain, by gravity, to respective steam header. Water pockets, or an improperly drained steam header will provide wet steam, causing improper operation of tumble dryer. If pockets or improper drainage cannot be eliminated, install a bypass trap to drain condensate from the low point in the steam header to the return.

- In both steam supply and steam return line, it is recommended that each have a pipe union and shut-off valve. This will enable you to disconnect the steam connections and service the tumble dryer while your laundry facility is in operation.
- Connect the steam solenoid valve to the related steam coil inlet connection with nipples, flex hoses, unions and tees.
- Strainers may require cleaning due to materials from hoses or pipes.
- Install vacuum breaker (optional), bucket trap with built-in strainer and check valve. For successful operation of tumble dryer, install trap 18 inches [460 mm] below coil and as near to the tumble dryer as possible. Inspect trap carefully for inlet and outlet markings and install according to trap manufacturer's instructions. If steam is gravity returned to boiler, omit trap but install vacuum breaker and check valve in return line near tumble dryer. Gravity return requires entire return plumbing be below steam coil outlets.
- Install union and shut-off valve in return line and make final pipe connections to return header.

NOTE: To prevent water hammering, route return lines below outlets of steam coils.

NOTE: Steam inlet lines of each dryer should be trapped to keep line condensation from going into steam coils.

NOTE: IEC machines are shipped with BSPT adapters in the lint compartment. Not for stack machines.

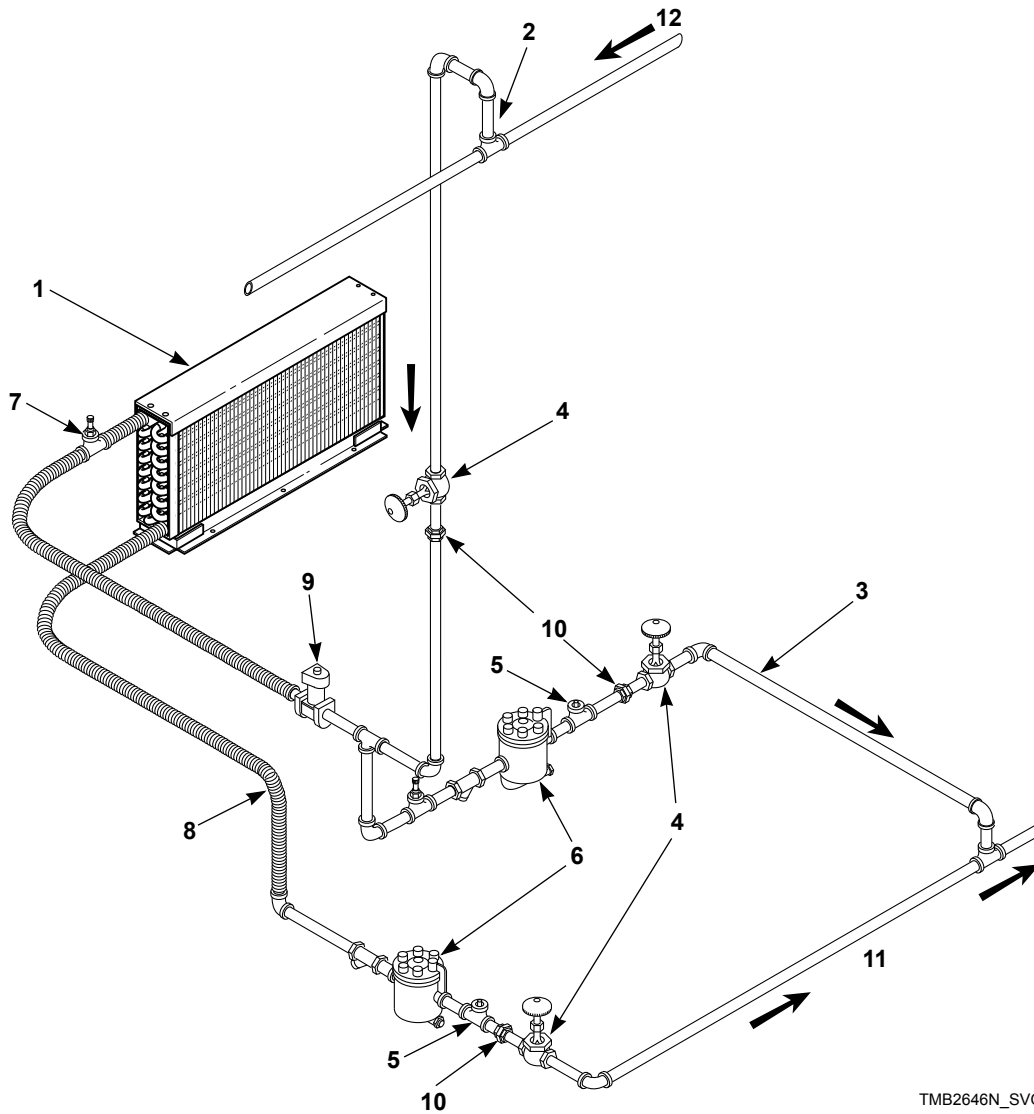

NOTE: Refer to *Table 36* for sizing of steam lines. Piping must also be sized accordingly for length of runs and number of elbows.

- 1. Steam Coil
- 2. 12 in. [300 mm] Riser
- 3. Condensate Return Line from Supply Line
- 4. Shut-Off Valve
- 5. Check Valve
- 6. Trap with Built-In Strainer
- 7. Vacuum Breaker (Optional)
- 8. 18 in. [460 mm] Drop Recommended (not above outlet)
- 9. Solenoid Valve (Supplied with machine)
- 10. Union
- 11. Return
- 12. Supply

Figure 24

Model	Steam Pressure PSI [bar]	Minimum Supply Pipe Diameter	Steam Trap Size* Pounds Condensate/ Hour [Kilograms Con- densate/Hour]
025/030 Series	80-100 [5.3-6.9]	3/4 NPT	134 [60.8]
035 Series	80-100 [5.3-6.9]	3/4 NPT	166 [75.3]
T30 Series	80-100 [5.3-6.9]	3/4 NPT	110 [49.9]

* Based on 100 psi.

Table 36

Piping Recommendations

- Trap each steam coil individually. Always keep the trap clean and in good working condition.
- When tumble dryer is on the end of a line of equipment, extend header at least 4 feet [1.2 m] beyond tumble dryer. Install shut-off valve, union, check valve and bypass trap at end of line. If gravity return to boiler, omit trap.
- Insulate steam supply and return lines for safety of operator and safety while servicing tumble dryer.

IMPORTANT: Steam trap must be installed a minimum of 18 inches [460 mm] recommended below the steam coil outlet connections.

4. Install a shut-off valve to each steam trap.
5. Connect to the condensate return lines.
6. For steam solenoid valve wiring connections, refer to Wiring Diagram supplied with tumble dryer.

	WARNING
<p>All system components must have a 125 psig [8.6 bar] working pressure. Shut-off valves must be installed upstream of the steam solenoid valve and downstream of each steam trap so components can be isolated for maintenance or emergency purposes. All components (solenoid valve, traps) must be supported to minimize loads on the tumble dryer steam coil connections.</p>	
W701R1	

Installing Steam Trap and Making Condensate Return Connections

The steam trap must be installed and the coil outlet connections must be connected to the condensate return lines. The following steps outline the procedure for installing the steam trap and connecting the condensate return lines. Refer to *Figure 24* for typical installations.

1. Use flexible lines between steam inlet solenoid and steam coils, as well as outlet between steam coil and traps.
2. If necessary, install a strainer at the end of each flexible hose.
3. Install a steam trap to each strainer.

Adjustments

Adjustments

	WARNING
<p>To reduce the risk of electric shock, fire, explosion, serious injury or death:</p> <ul style="list-style-type: none"> • Disconnect electric power to the tumble dryer before servicing. • Close gas shut-off valve to gas tumble dryer before servicing. • Close steam valve to steam tumble dryer before servicing. • Never start the tumble dryer with any guards/panels removed. • Whenever ground wires are removed during servicing, these ground wires must be reconnected to ensure that the tumble dryer is properly grounded. 	
W002R1	

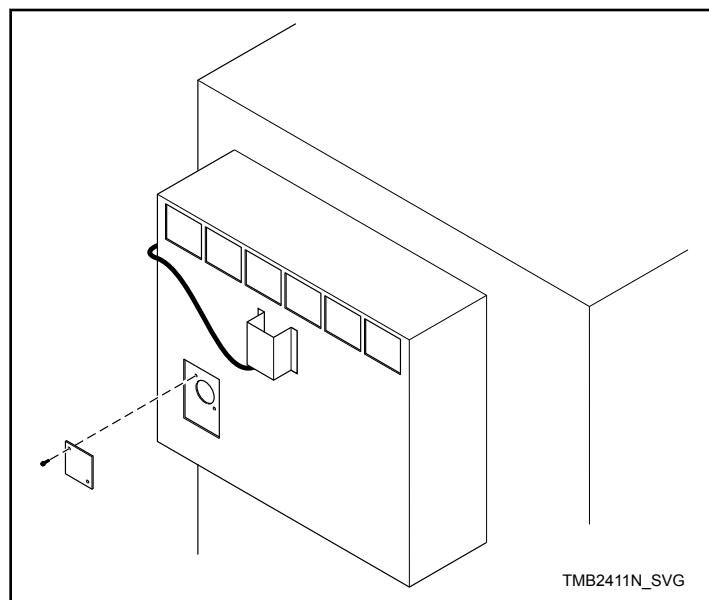

Figure 25

Gas Burner Air Shutter

NOTE: Air inlet shutters on the burner must be adjusted so sufficient air is metered into the system for proper combustion and maximum efficiency. Before adjusting the inlet shutters be sure that all lint is removed from lint compartments and lint screen.

Air shutter adjustments will vary from location to location and will depend on the vent system, number of units installed, make-up air and line gas pressure. Opening the shutter increases the amount of primary air supplied to the burner while closing the shutter decreases the primary air supply. Adjust air shutter as follows:

Refer to *Figure 25*.

1. Remove the burner inspection hole plate.

2. Start the tumble dryer and check the flame pattern. If the flame pattern is straight up, insufficient air is flowing through the tumble dryer. A flame pattern that flares to the right and left indicates no air is flowing through the tumble dryer. Correct air and gas mixture is indicated if the flame pattern is primarily blue, with small yellow tips, and bends to the right of the heater section. Too little air is indicated if the flame is yellow, lazy and smokey. (A whistling sound from burner could also be caused by an improper air shutter setting.)
3. To adjust the air shutter, loosen air inlet shutter adjusting screw.
4. Open or close air shutter as necessary to obtain proper flame intensity.
5. After air shutter is adjusted for proper flame, tighten air shutter adjusting screw securely.

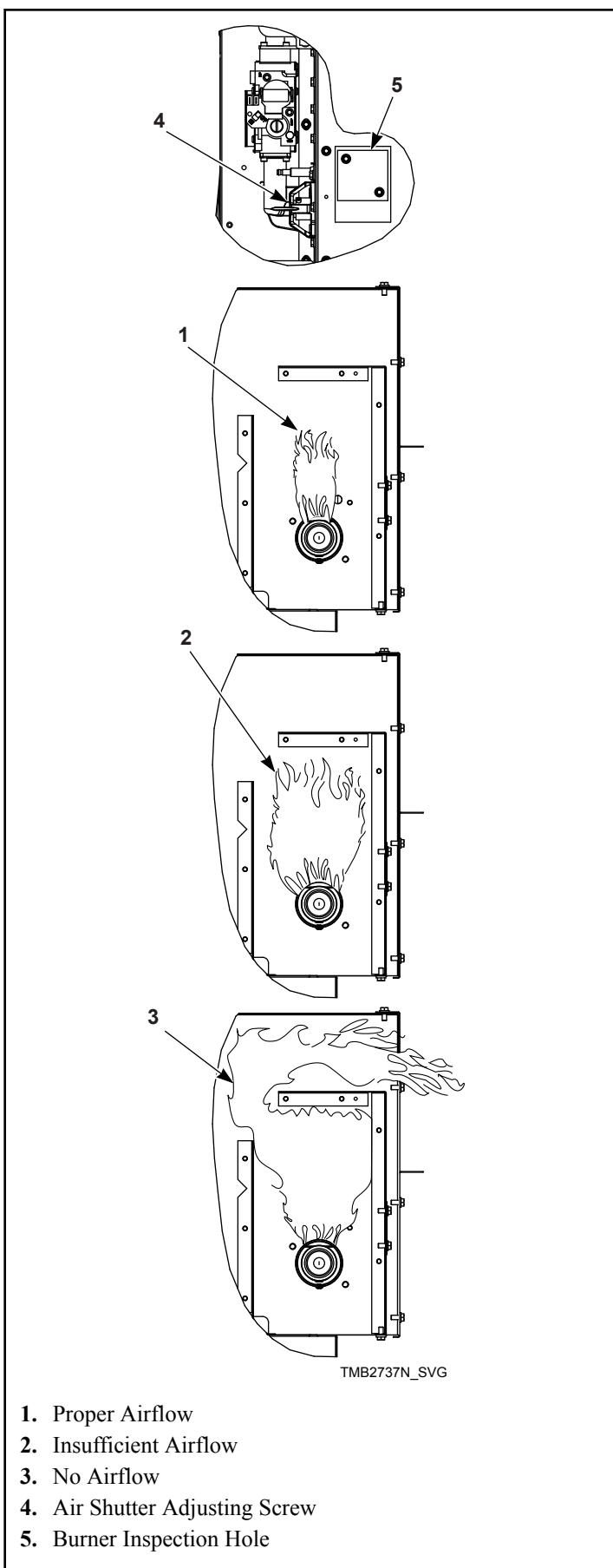

Figure 26

Airflow Switch

The airflow switch is set at the factory for proper operation. No adjustment necessary.

The airflow switch operation may be affected by shipping wire tie still in place, lack of make-up air, or an obstruction in the exhaust duct. These should be checked and the required corrective action taken.



WARNING

The tumble dryer must not be operated if the airflow switch does not operate properly. Faulty airflow switch operation may cause an explosive gas mixture to collect in the tumble dryer.

W072R1

IMPORTANT: Airflow switch vane must remain closed during operation. If it opens and closes during the drying cycle, this indicates insufficient airflow through the tumble dryer. If switch remains open, or pops open and closed during the cycle, the heating system will shut off. The cylinder and fan will continue to operate even though the airflow switch is indicating insufficient airflow.

NOTE: To properly mount the airflow switch bracket, or in case of a load not drying, the airflow switch bracket may need to be checked for proper alignment. Be sure the locator pins are securely in their respective holes before tightening the bracket mounting screws. This will assure proper alignment of the airflow switch arm in the channel of the airflow switch bracket and prevent binding of the arm.

Loading Door Switch

The door switch should be adjusted so the cylinder stops when door is opened 0.79 inches [20 mm]. This switch is a normally open switch and is closed by the switch actuator when the door is closed. If adjustment is required, refer to *Figure 27* and proceed as follows:

1. Close door and start tumble dryer, slowly open loading door. Cylinder and heat system should shut off when door is open 0.79 inches [20 mm].
2. Slowly close the loading door. When door is 0.79 inches [20 mm] or less from being fully closed, the door switch actuating bracket (located on the door) should depress the button and the switch arm with an audible "click."
3. If the actuating bracket does not operate the switch at the appropriate door closure, bend the actuating switch arm in or out to achieve proper actuation.

Manual Resettable Thermostat

NOTE: The manual resettable thermostat is located as follows: 025-030-035-055 - inside access panel on rear of machine near blower motor. T30-T45 - on blower housing top surface behind rear guard.

If thermostat trips, contact a qualified service technician.

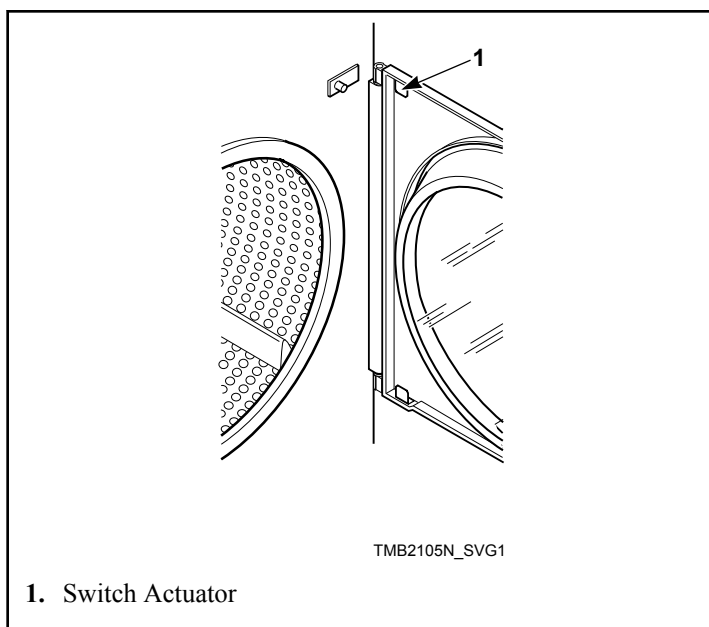

Figure 27

Door Strike

The door strike must be adjusted to have sufficient tension to hold loading door closed against force of the load tumbling against it. There is proper adjustment of pull force when 8 to 15 pounds [35.6 N – 66.7 N] is required to open door.

If adjustment is required, refer to *Figure 28* and proceed as follows:

1. To adjust, open door, loosen acorn nut, and turn door strike screw in or out as required.
2. Retighten acorn nut.

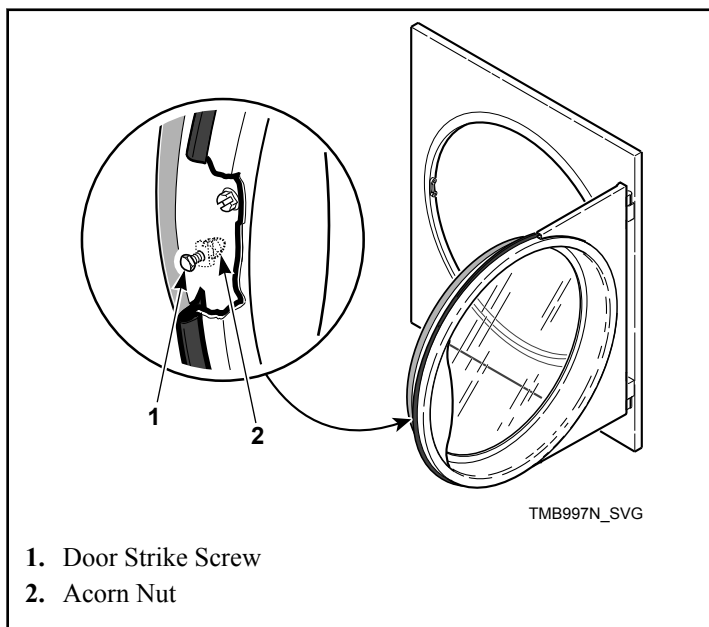

Figure 28

Before You Call for Service

Won't Start	Won't Heat	Clothes Not Dry	Possible Reason – Corrective Actions
•			Insert correct coin(s) or valid card if applicable.
•			Close the loading door tightly.
•			Close lint panel tightly.
•			Press the PUSH-TO-START or START pad/button.
•			Be sure power cord is plugged all the way into the electrical outlet and hard or direct wire connections are tight.
•			Check the main fuse and circuit breaker.
•			Check fuses located in the machine.
	•		Insufficient airflow.
	•		Gas shut-off valve in OFF position.
	•		Are controls properly set?
	•		Broken drive belt. Call the service person.
	•	•	Tumble dryer is in Cool Down Mode.
	•	•	Lint screen clogged. Clean lint screen.
	•	•	Exhaust duct to outside is blocked. Clean out.

Removing Tumble Dryer from Service

1. Turn off electrical supply external to machine.
2. Turn off gas supply external to machine.
3. Turn off manual gas shut-off valve on machine.
4. Turn off steam supply external to machine.
5. Remove all electric, gas and steam connections.

Disposal of Unit

This appliance is marked according to the European directive 2002/96/EC on Waste Electrical and Electronic Equipment (WEEE).

This symbol on the product or on its packaging indicates that this product shall not be treated as household waste. Refer to *Figure 29*. Instead it shall be handed over to the applicable collection point for the recycling of electrical and electronic equipment. Ensuring this product is disposed of correctly will help prevent potential negative consequences for the environment and human health which could otherwise be caused by inappropriate waste handling of this product. The recycling of materials will help to conserve natural resources. For more detailed information about recycling of this product, please contact the local city office, household waste disposal service, or the source from which the product was purchased.

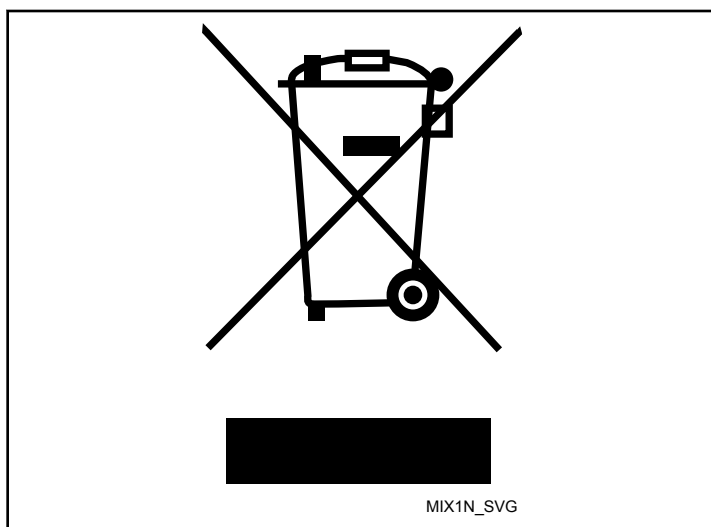

Figure 29